

Spannzange / collet ER25 DIN6499
 Spannereich / clamping range: 1,0 - 16,0

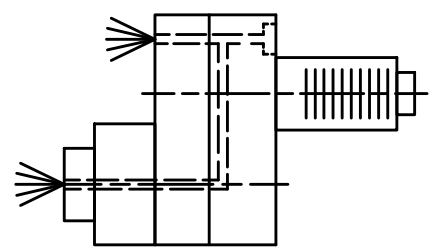

Innen- und Aussenkuehlung / Inside and outside coolant supply
 Kein Trockenlauf / No dry run
 Kuehlmittelfiltrierung 50μ / coolant filtration 50μ

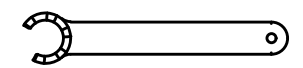
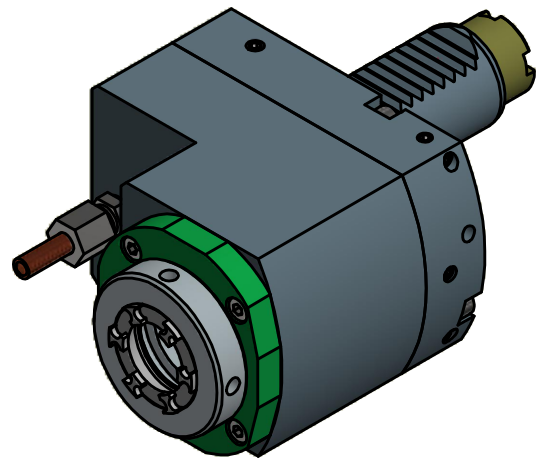

Spannzangenschlüssel für innenliegende Mutter
 Clamping wrench for internal collet
 225AX

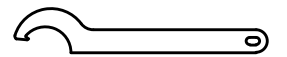

Hakenschlüssel mit Nase
 Hook wrench with nose end
 DIN1810 A 58x62

Copyright **EWS Tool Technologies**
 Weitergabe und Vervielfaeltigung dieser Unterlage, Verwertung und Mitteilung ihres Inhalts nicht gestattet, soweit nicht ausdrecklich zugestanden. Zuwiderhandlungen verpflichten zu Schadenersatz.

Bemerkung - Note
 Nicht ohne Kuehlmittel betreiben!
 Not for use without coolant-fluid!

Technische Daten - technical data
 Weight = 3.306 [kg]
 Torque max. (M1/M2) = 40 / 80 [Nm]
 Speed max. (n1/n2) = 6000 / 3000 [1/min]
 Gear ratio (i)=n1:n2 = 2:1
 Pressure (pmax) = 70 [bar]

Benennung - Title
Axial Bohr u. Fräskopf achsversetzt
Ax. drill. and mill. head offset

EWS Tool Technologies
 EWS Weigle GmbH & Co. KG
 Maybachstr. 1
 D-73066 Uehingen
 www.ews-tools.de
 Nr. - No.
50.3025LT10RIKI2IM

Technische Aenderungen vorbehalten!
 Subject to technical modifications!
 IDENT: DEWS053149
 REV: -/A
 MNR.
131510

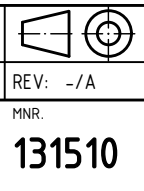

QR