

Innen- und Aussenkuehlung / Inside and outside coolant supply
Kein Trockenlauf / No dry run
Kuehlmittelfiltrierung <math>< 50\mu</math> / coolant filtration <math>< 50\mu</math>

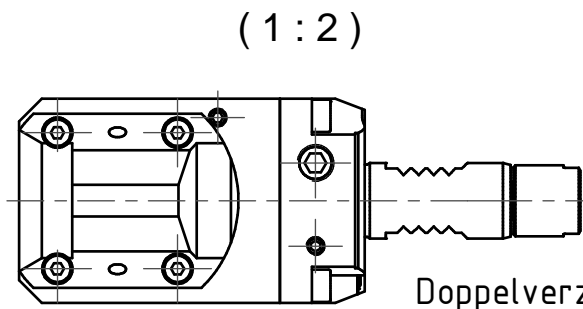

Doppelverzahnung Lizenz Traub
double tooth system licence Traub

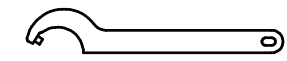
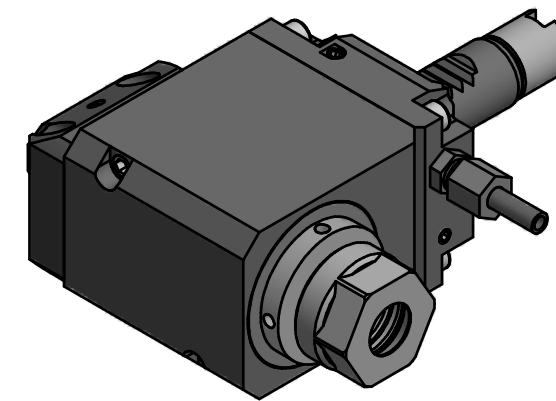

Hakenschlüssel
mit Zapfen
Hook wrench
with fixed pin
DIN1810 B 40x42

Copyright **EWS Tool Technologies**
Weitergabe und Vervielfaeltigung dieser Unterlage,
Verwertung und Mitteilung ihres Inhalts nicht
gestattet, soweit nicht ausdrecklich zugestanden.
Zuwiderhandlungen verpflichten zu Schadenersatz.

Bemerkung - Note
Nicht ohne Kuehlmittel betreiben!
Not for use without coolant-fluid!

Technische Daten - technical data	
Weight	= 2.616 [kg]
Torque max. (M1/M2)	= 11 / 5,5 [Nm]
Speed max. (n1/n2)	= 6000 / 12000 [1/min]
Gear ratio (i)=n1:n2	= 1:2
Pressure (pmax)	= 70 [bar]

Benennung - Title
Radial Bohr und Fräskopf
Radial drilling and milling head



Nr. - No.
60.2020C100RLIKI1W

Technische Aenderungen vorbehalten!
Subject to technical modifications!

IDENT: D-EWS-213109



REV: -/-

MNR.

152891

