

Spannzange / Collet ER16 DIN6499  
 Spannbereich / Clamping range: 1,0 - 10,0

Gewindebohrzange / Tapping Collet  
 ET-1-16 M1-M6

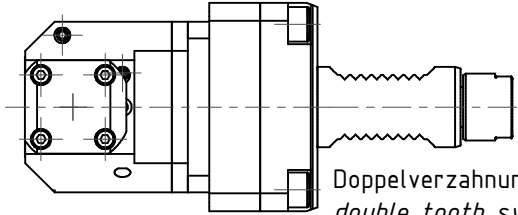

Doppelverzahnung Lizenz Traub  
 double tooth system licence Traub

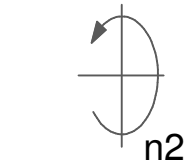
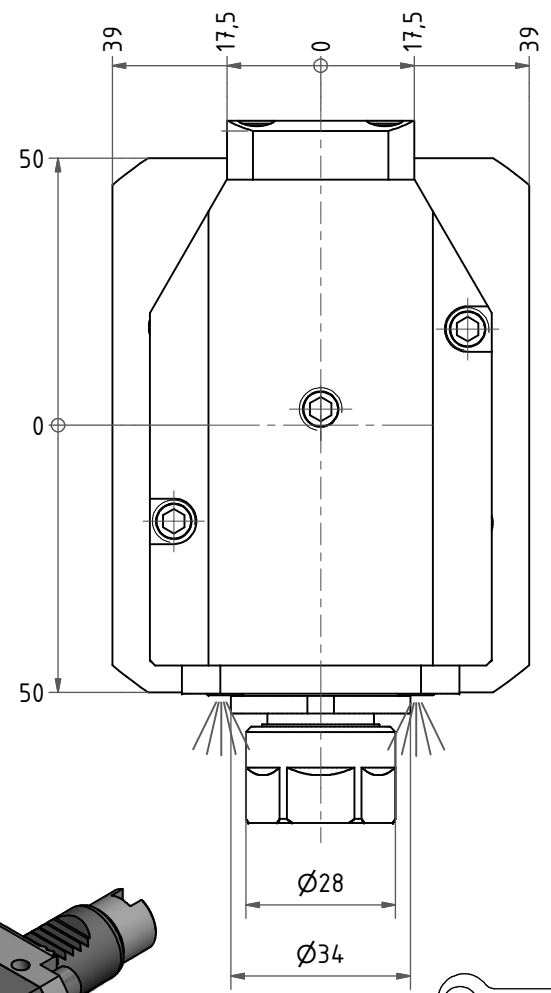

Hakenschlüssel  
 mit Nase  
 Hook wrench with  
 nose end  
 DIN1810 A 34x36

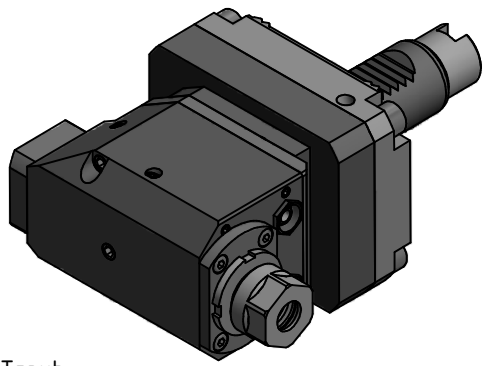

Copyright **EWS Tool Technologies**  
 Weitergabe und Vervielfältigung dieser Unterlage,  
 Verwertung und Mitteilung ihres Inhalts nicht  
 gestattet, soweit nicht ausdrücklich zugestanden.  
 Zuwiderhandlungen verpflichten zu Schadenersatz.

Bemerkung - Note

Technische Daten - technical data  
 Weight = 5,141 [kg]  
 Torque max. (M1/M2) = 15 / 5 [Nm]  
 Speed max. (n1/n2) = 6000 / 18000 [1/min]  
 Gear ratio (i)=n1:n2 = 1:3

Benennung - Title  
**Radial Bohr und Fräskopf**  
**Radial drilling and milling head**

**EWS** Tool Technologies  
 EWS Weigelt GmbH & Co. KG  
 Maybachstr. 1  
 D-73066 Uhingen  
 www.ews-tools.de  
 Nr. - No.  
**60.3016G300RL13W**

Technische Änderungen vorbehalten!  
 Subject to technical modifications!  
 IDENT: DEWS039049  
 MNR.  
**153365**

