

min. 89,5
max. 93

Spannzange / collet ER32 DIN6499
Spannbereich / clamping range: 2,0 - 20,0
Gewindebohrzange / tapping collet
ET-1-32 M5-M12

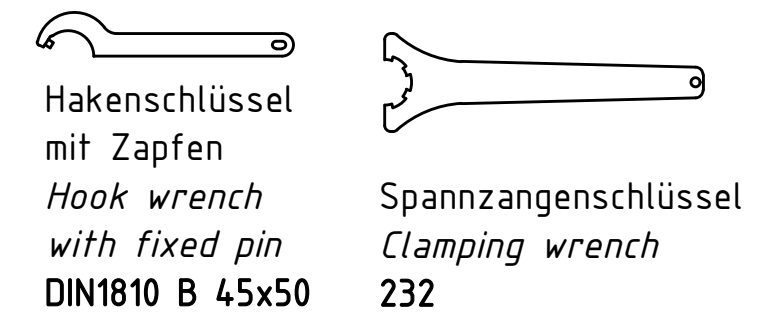
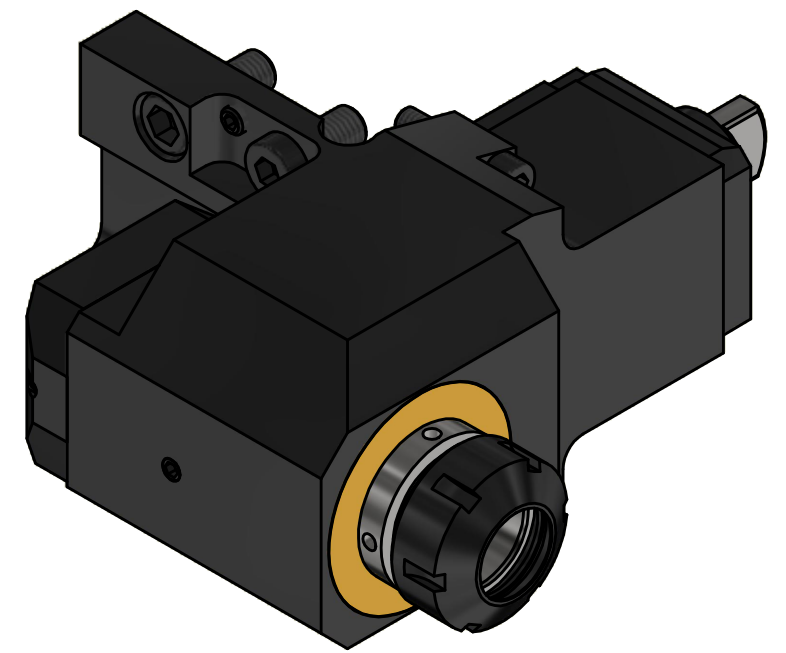
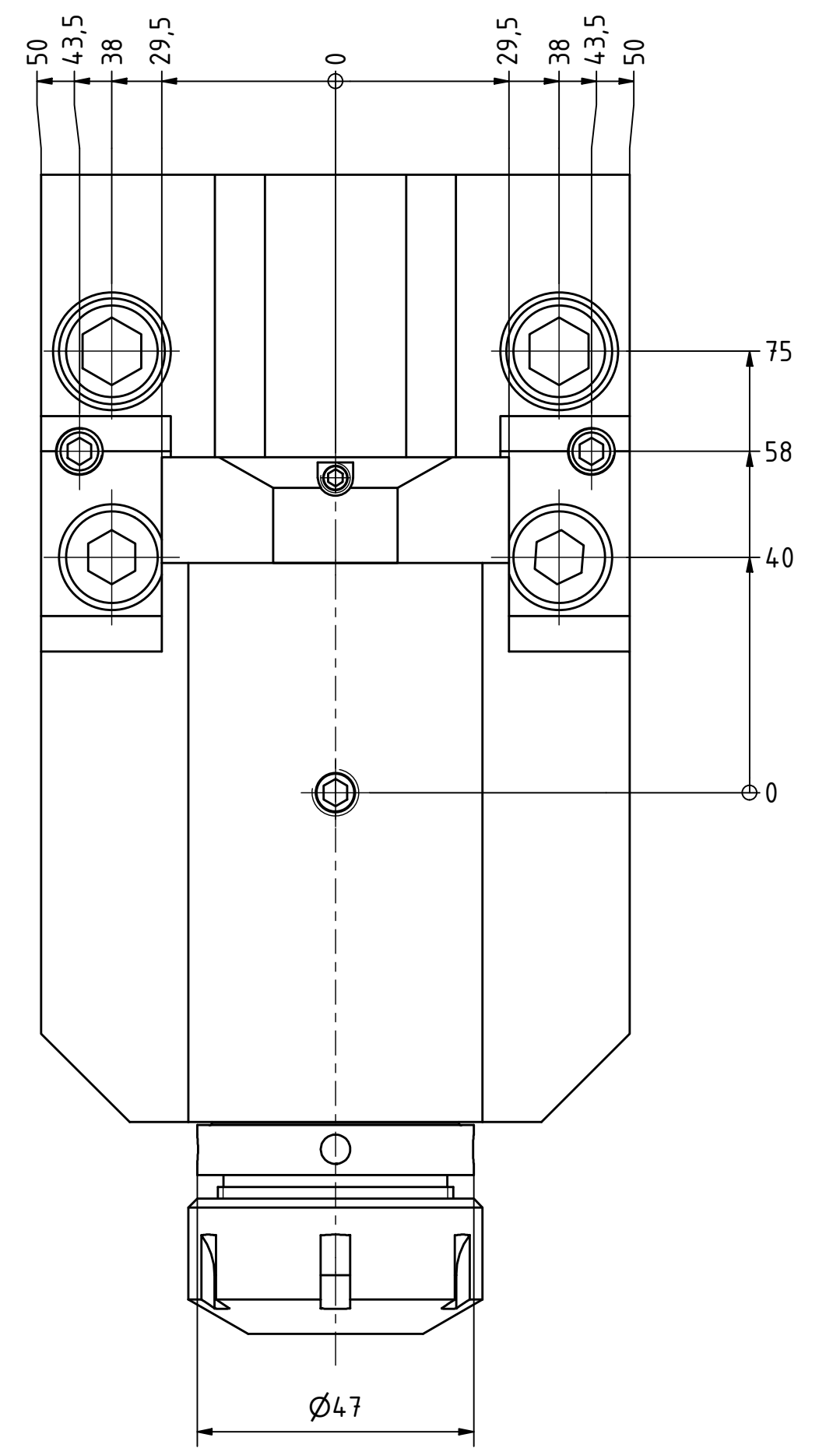
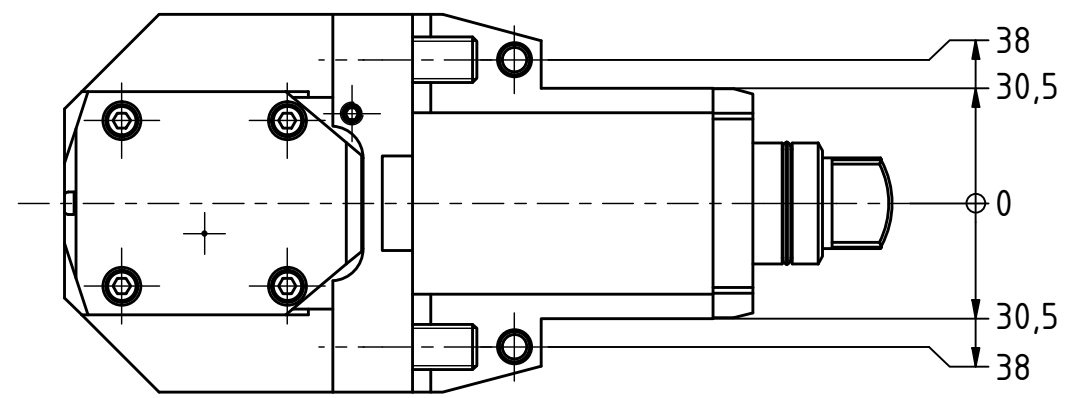
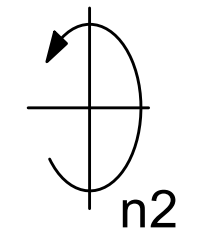

Copyright EWS Tool Technologies
Weitergabe und Vervielfältigung dieser Unterlage, Verwertung und Mitteilung ihres Inhalts nicht gestattet, soweit nicht ausdrücklich zugestanden. Zuwiderhandlungen verpflichten zu Schadenersatz.

Bemerkung - Note	Technische Daten - technical data Weight = 9,435 [kg] Torque max. (M1/M2) = 40 / 80 [Nm] Speed max. (n1/n2) = 5000 / 2500 [1/min] Gear ratio (i)=n1:n2 = 2:1	Benennung - Title Radial Bohr und Fräskopf <i>Radial drilling and milling head</i>	 EWS Weigle GmbH & Co. KG Maybachstr. 1 D-73066 Ulm/ingen www.ews-tool.de Nr. - No. 60.3232SL200BMTR12	Technische Änderungen vorbehalten! Subject to technical modifications! IDENT: DEWS149972 MNR. 145334	 QR
------------------	--	---	---	---	---------------