

Spannzange / collet ER32 DIN6499
 Spannereich / clamping range: 2,0 - 20,0

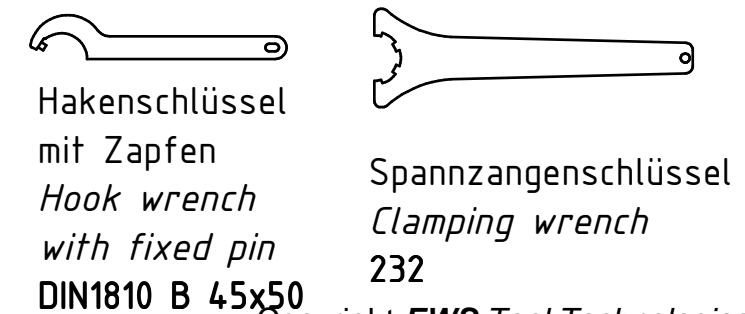
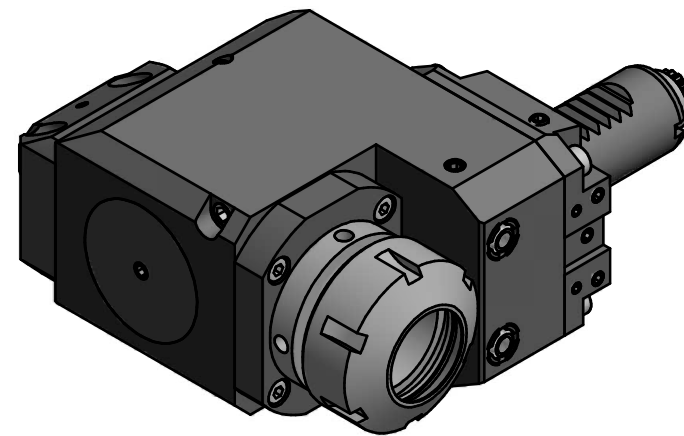
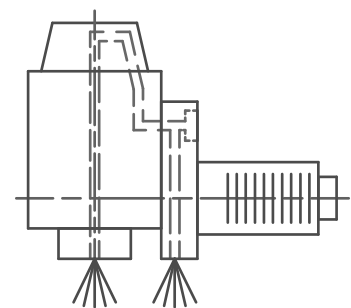

Copyright **EWS Tool Technologies**
 Weitergabe und Vervielfaeltigung dieser Unterlage,
 Verwertung und Mitteilung ihres Inhalts nicht
 gestattet, soweit nicht ausdruercklich zugestanden.
 Zuwiderhandlungen verpflichten zu Schadenersatz.

Innen- und Aussenkuehlung / Inside and outside coolant supply
 Kein Trockenlauf / No dry run
 Kuehlmittelfiltrierung 50μ / coolant filtration 50μ

Bemerkung - Note
 Nicht ohne Kuehlmittel betreiben!
 Not for use without coolant-fluid!

Technische Daten - technical data
 Weight = 4.098 [kg]
 Torque max. (M1/M2) = 25 / 25 [Nm]
 Speed max. (n1/n2) = 8000 / 8000 [1/min]
 Gear ratio (i)=n1:n2 = 1:1
 Pressure (pmax) = 70 [bar]

Benennung - Title
Radial Bohr und Fräskopf, zurückges
Radial drill. and mill. head offset



Nr. - No.
80.2532L5480RIK

Technische Aenderungen vorbehalten!
 Subject to technical modifications!

IDENT: D-EWS-149376



REV: A/-

MNR.

139774

