

Spannzange / collet ER25 DIN6499
 Spannungsbereich / clamping range: 1,0 - 16,0

Gewindebohrzange / tapping collet
 ET-1-25 M3-M10

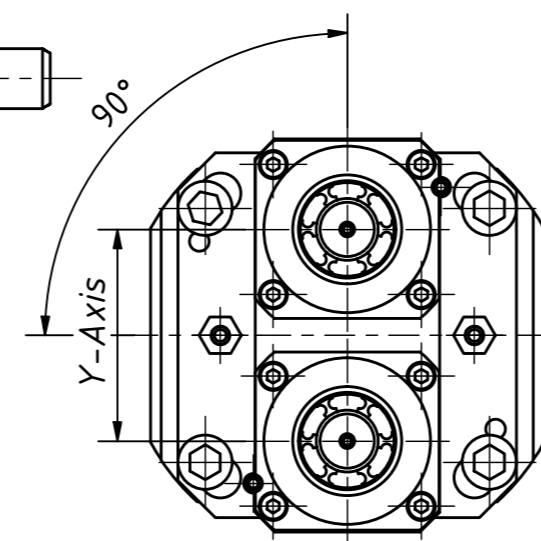

Kopf kann um 90° gedreht werden.
 head can be rotated 90°

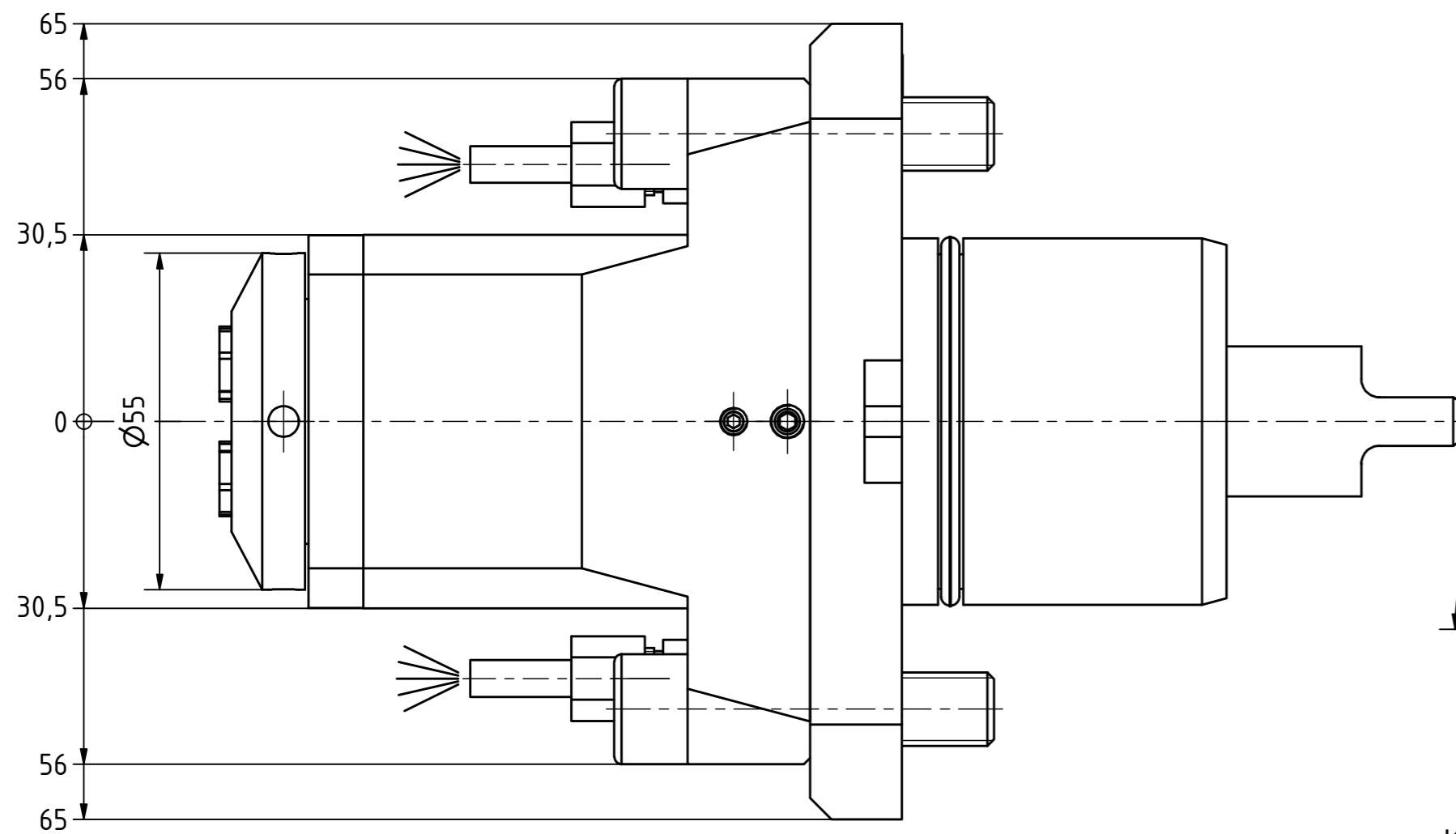
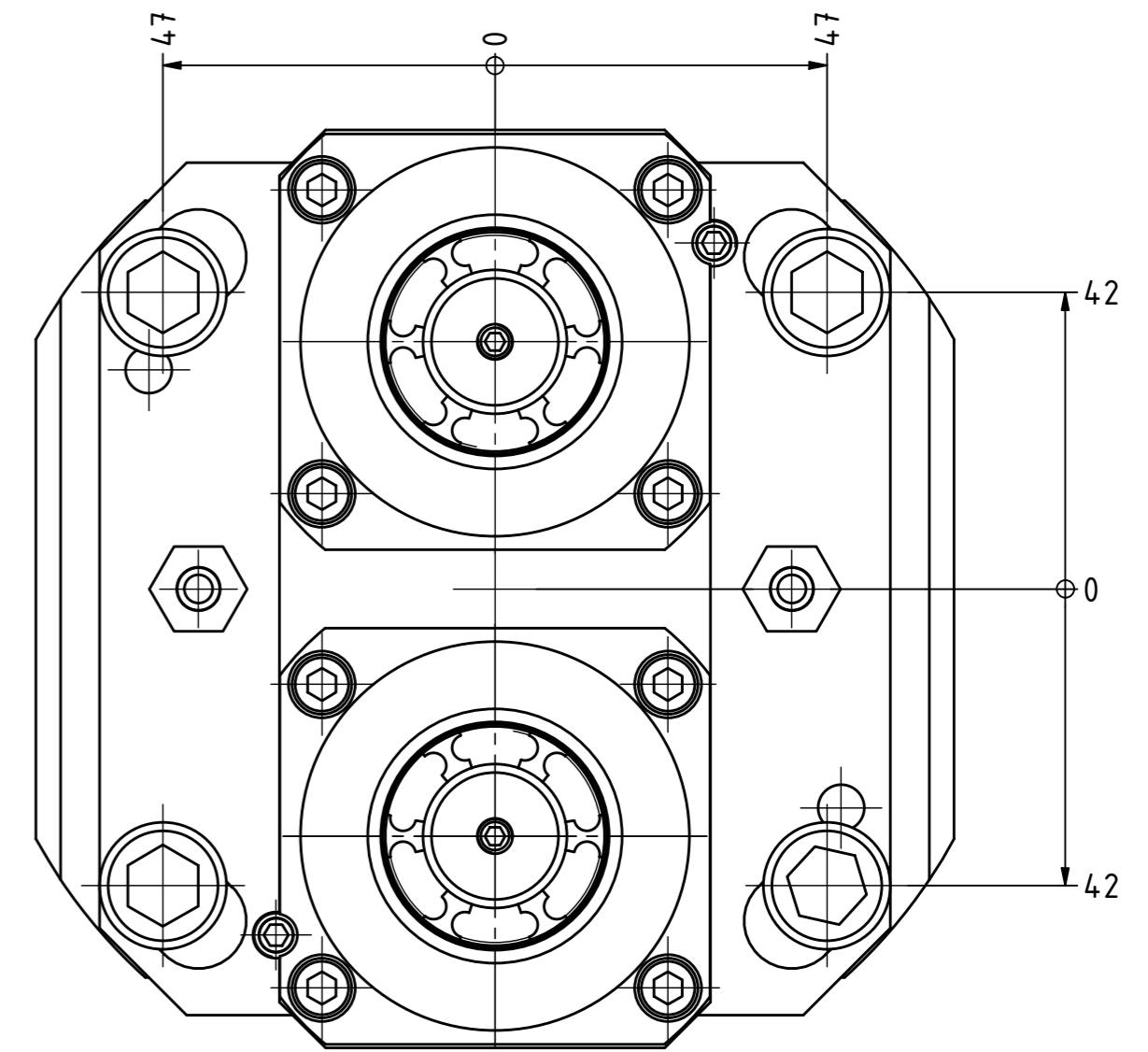
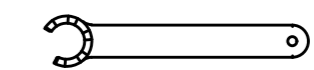
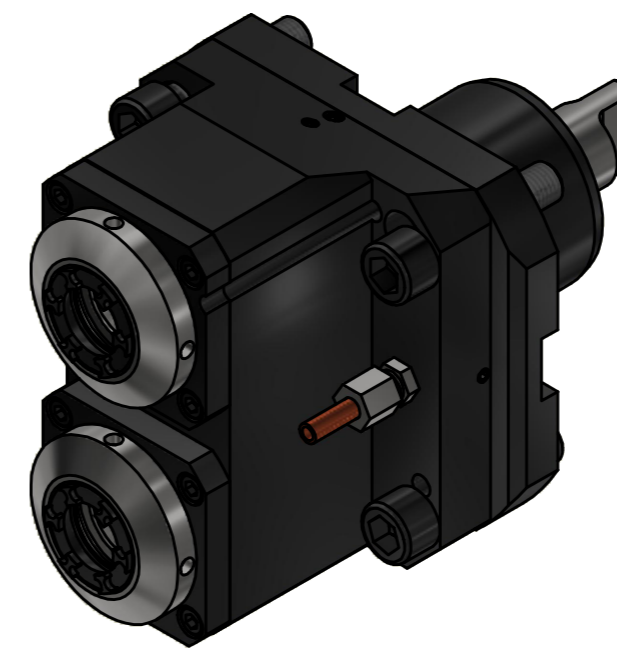

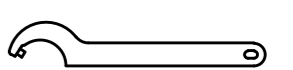

Spannzangenschlüssel für
 innenliegende Mutter
 Clamping wrench for
 internal collet
 225AX



Hakenschlüssel
 mit Zapfen
 Hook wrench
 with fixed pin
 DIN1810 B 52x55

Copyright **EWS Tool Technologies**
 Weitergabe und Vervielfältigung dieser Unterlage,
 Verwertung und Mitteilung ihres Inhalts nicht
 gestattet, soweit nicht ausdrücklich zugestanden.
 Zuwiderhandlungen verpflichten zu Schadenersatz.

Bemerkung - Note 	Technische Daten - technical data Weight = 7.935 [kg] Torque max. (M1/M2) = 30 / 30 30 [Nm] Speed max. (n1/n2) = 6000 / 6000 6000 [1/min] Gear ratio (i)=n1:n2 = 1:1 1:1	Benennung - Title Axial Bohr und Fräskopf Axial drilling and milling head	 EWS Weigle GmbH & Co. KG Maybachstr. 1 D-73066 Ulm/ingen www.ews-tools.de Nr. - No. 40.6025DYNLIMTK70	Technische Änderungen vorbehalten! Subject to technical modifications! IDENT: DEWS119732 MNR. 139131	
--------------------------	--	---	---	---	---