

Spannzange / collet ER25 DIN6499
Spannbereich / clamping range: 1,0 - 16,0

Gewindebohrzange / tapping collet
ET-1-25 M3-M10

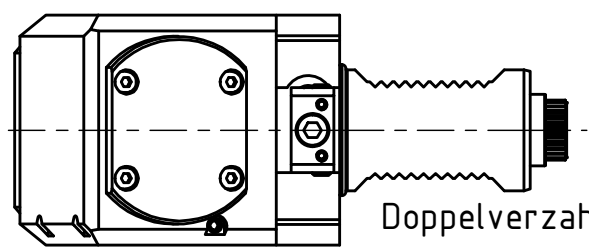

Doppelverzahnung Lizenz Traub
double tooth system licence Traub

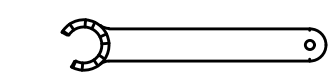
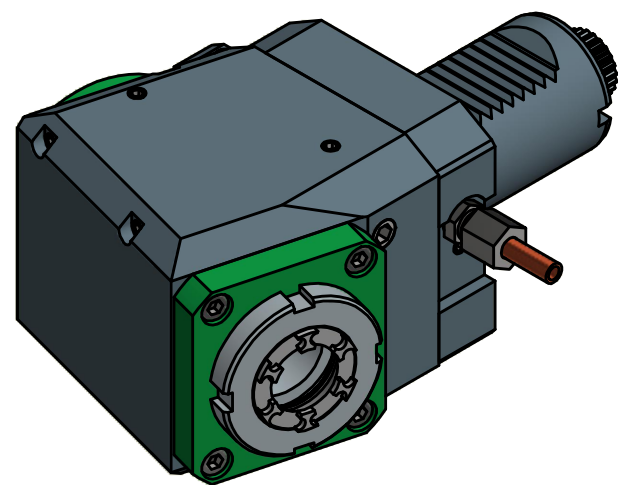

Spannzangenschlüssel für
innenliegende Mutter
Clamping wrench for
internal collet
225AX

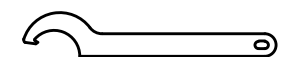

Hakenschlüssel
mit Nase
Hook wrench with
nose end
DIN1810 A 45x50

Copyright **EWS Tool Technologies**
Weitergabe und Vervielfaeltigung dieser Unterlage,
Verwertung und Mitteilung ihres Inhalts nicht
gestattet, soweit nicht ausdrecklich zugestanden.
Zuwiderhandlungen verpflichten zu Schadenersatz.

Bemerkung - Note

Technische Daten - technical data

Weight	= 4.688 [kg]
Torque max. (M1/M2)	= 50 / 50 [Nm]
Speed max. (n1/n2)	= 6000 / 6000 [1/min]
Gear ratio (i)=n1:n2	= 1:1

Benennung - Title

Radial Bohr und Fräskopf
Radial drilling and milling head

EWS
Tool Technologies

EWS Weigle GmbH & Co. KG
Maybachstr. 1
D-73066 UHINGEN
www.ews-tools.de

Technische Aenderungen vorbehalten!
Subject to technical modifications!

IDENT: D-EWS-166727

REV: -/-

MNR.

139658

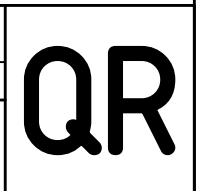

Nr. - No.
60.4025CTXRLTKW75IM