

Spannzange / collet ER32 DIN6499
 Spannbereich / clamping range: 2,0 - 20,0

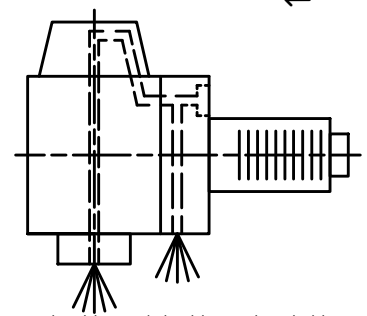
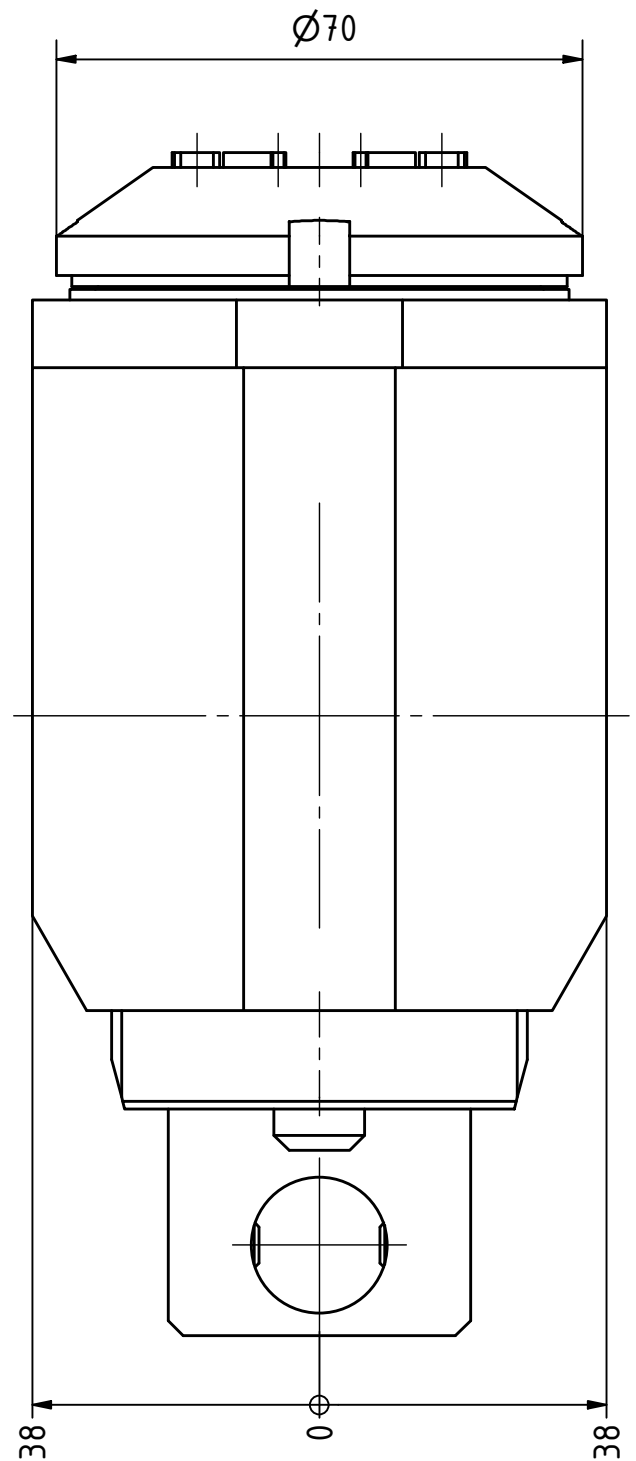
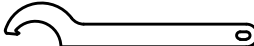

Innen- und Aussenkuehlung / Inside and outside coolant supply
 Kuehlmittelfiltrierung 50μ / coolant filtration 50μ

 Spannzangenschlüssel für
 innenliegende Mutter
 Clamping wrench for
 internal collet
232AX

 Hakenschlüssel
 mit Nase
 Hook wrench with
 nose end
DIN1810 A 68x75

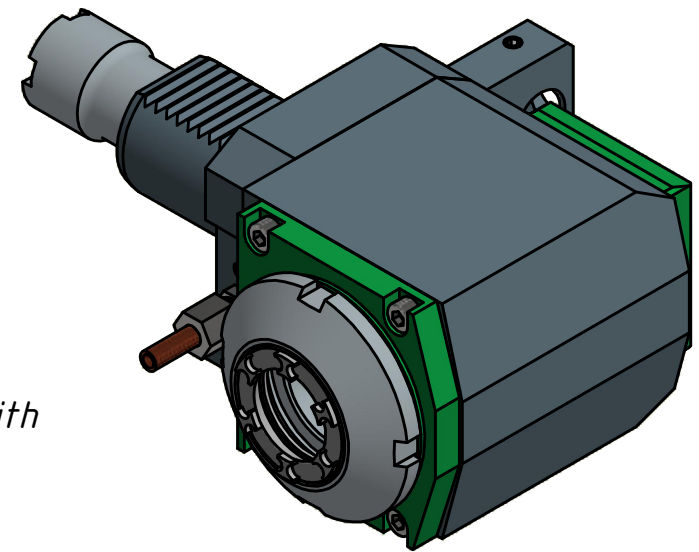

Copyright **EWS Tool Technologies**
 Weitergabe und Vervielfaeltigung dieser Unterlage,
 Verwertung und Mitteilung ihres Inhalts nicht
 gestattet, soweit nicht ausdrecklich zugestanden.
 Zuwiderhandlungen verpflichten zu Schadenersatz.

Bemerkung - Note
 Für Trockenlauf geeignet!
 Use without coolant fluid allowed!

Technische Daten - technical data
 Weight = 5.597 [kg]
 Torque max. (M1/M2) = 50 / 50 [Nm]
 Speed max. (n1/n2) = 6000 / 6000 [1/min]
 Gear ratio (i)=n1:n2 = 1:1
 Pressure (pmax) = 70 [bar]

Benennung - Title
Radial Bohr und Fräskopf
Radial drilling and milling head

EWS Tool Technologies
 EWS Weigele GmbH & Co. KG
 Maybachstr. 1
 D-73066 Utingen
 www.ews-tools.de
 Nr. - No.
60.4032LB15LIKDIM

Technische Aenderungen vorbehalten!
 Subject to technical modifications!
 IDENT: D-EWS-161295
 MNR.
145388

