

Spannzange / collet ER32 DIN6499
Spannbereich / clamping range: 2,0 - 20,0

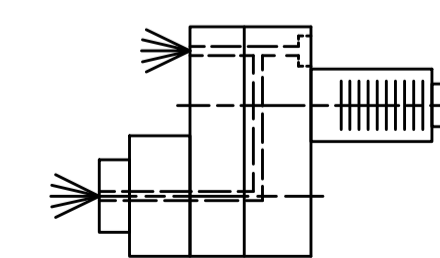
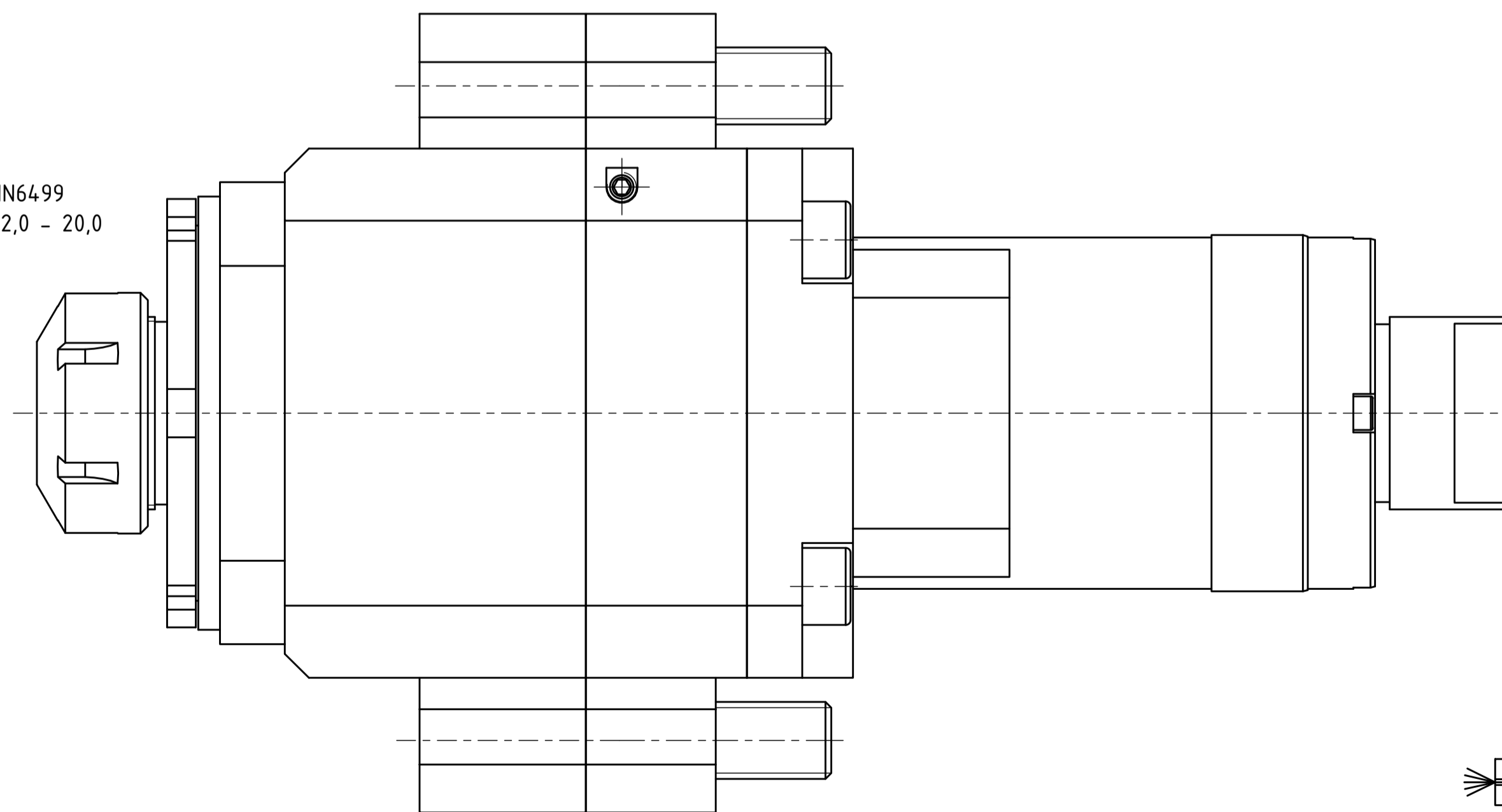
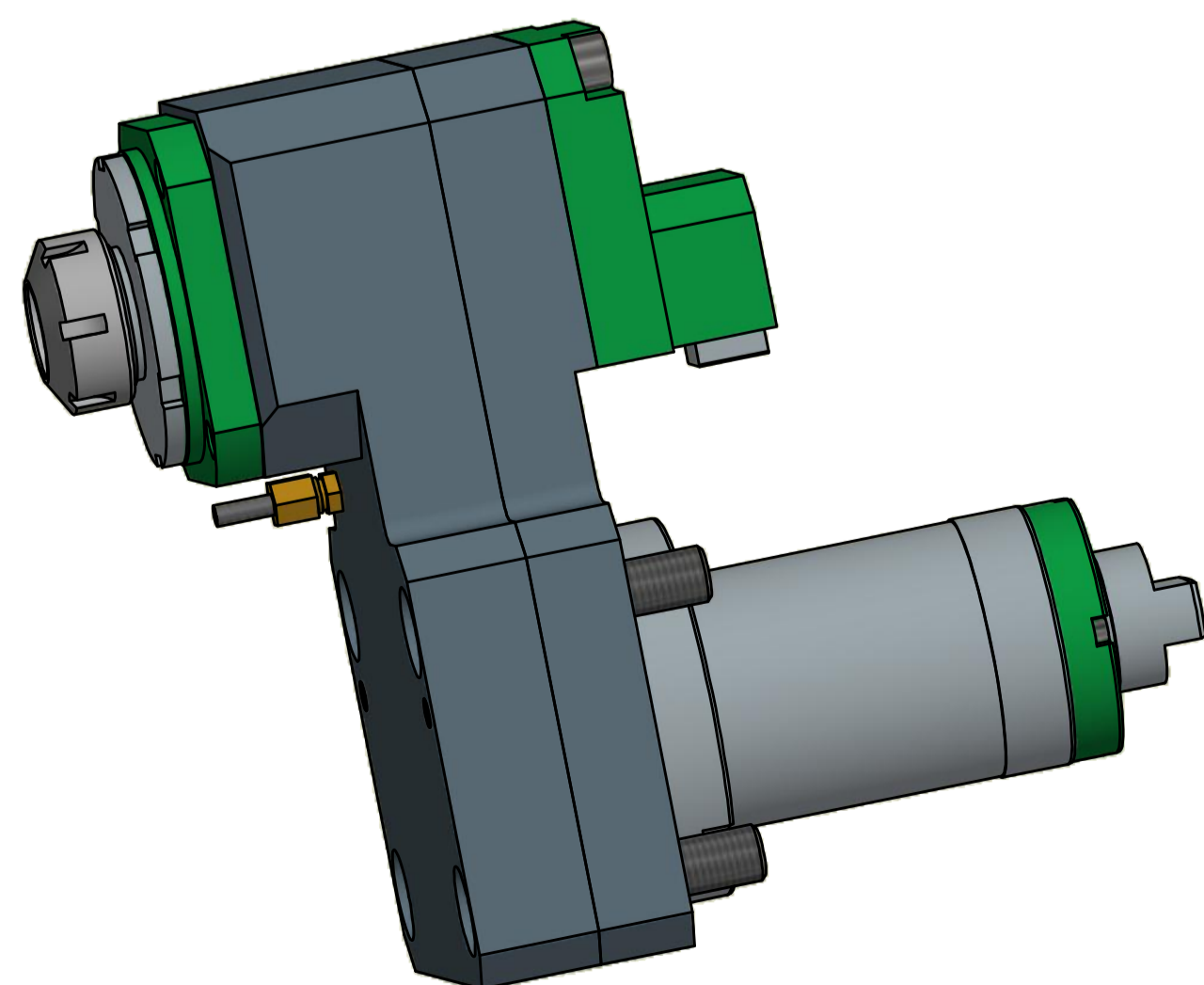
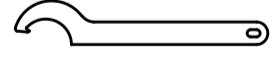

Innen- und Aussenkuehlung / Inside and outside coolant supply
Kuehlmittelfiltrierung=50µ / coolant filtration=50µ

Hakenschlüssel
mit Nase
Hook wrench with
nose end
DIN1810 A 80x90

Spannzangenschlüssel
Clamping wrench
232

Benennung - Note
Für Trockenlauf geeignet!
Use without coolant fluid allowed!

Technische Daten - Technical data
Weight = 25.905 [kg]
Torque max. (M1/M2) = 100 / 100 [Nm]
Speed max. (n1/n2) = 4.000 / 4.000 [1/min]
Gear ratio (i)=n1:n2 = 1:1
Pressure (pmax) = 70 [bar]

Benennung - Title
Axial Bohr u. Fräskopf achsversetzt
Ax. drill. and mill. head offset

EWS Werkzeug GmbH & Co. KG
Kruppstr. 1
47200 Lörkingen
www.ews-tool.de
Nr. - Art.
50.10832HOWAIKD

Technische Änderungen vorbehalten!
Subject to technical modifications!
IDENT: D-EWS-095836

REV: -/-
NR:
151322

QR

Copyright EWS Tool Technologies
Weitergabe und Vervielfältigung dieser Unterlage,
Verwertung und Mitteilung ihres Inhalts nicht
gestattet, soweit nicht ausdrücklich zugestanden.
Zu widerhandlungen verpflichten zu Schadenersatz.