

Spannzange / collet ER32 DIN6499
 Spannbereich / clamping range: 2,0 - 20,0

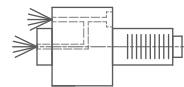

Innen- und Aussenkuehlung / Inside and outside coolant supply
 Kuehlmittelfiltrierung=50µ / coolant filtration=50µ

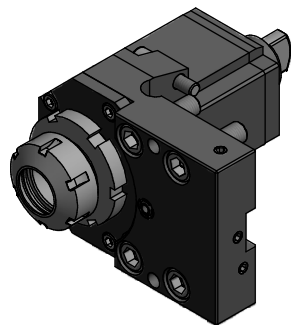
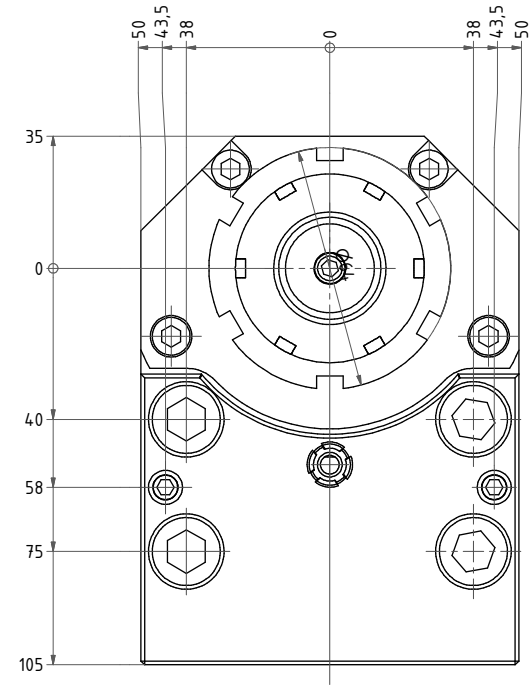
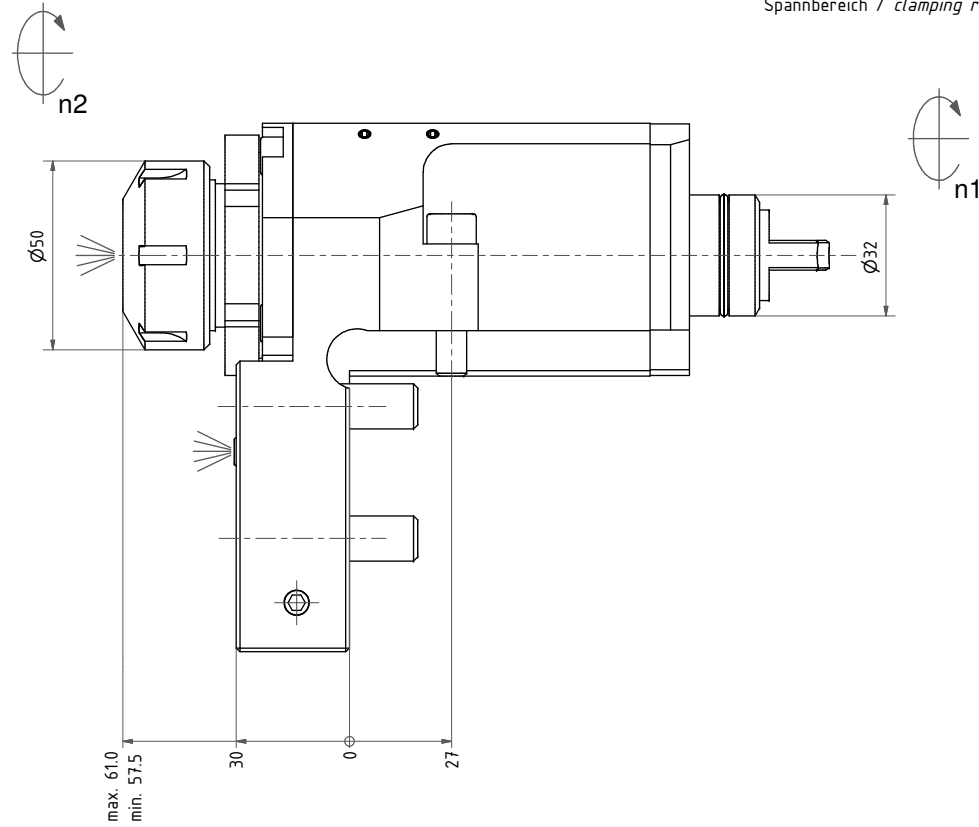
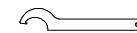

Hakenschlüssel
 mit Nase
 Hook wrench with
 nose end
 DIN1810 A 58x62



Spannzangenschlüssel
 Clamping wrench
 232

Copyright **EWS Tool Technologies**
 Weitergabe und Vervielfaeltigung dieser Unterlage,
 Verwertung und Mitteilung ihres Inhalts nicht
 gestattet, soweit nicht ausdrecklich zugestanden.
 Zuwiderhandlungen verpflichten zu Schadenersatz.

<p>Bemerkung - Note Für Trockenlauf geeignet! Use without coolant fluid allowed!</p>	<p>Technische Daten - Technical data Weight = 5.634 [kg] Torque max. (M1/M2) = 50 / 50 [Nm] Speed max. (n1/n2) = 5000 / 5000 [1/min] Gear ratio (i)=n1:n2 = 1:1 Pressure (pmax) = 70 [bar]</p>	<p>Benennung - Title Axial Bohr und Fräskopf Axial drilling and milling head</p>	<p>EWS EWS Werkzeug GmbH & Co. KG Tool Technologies D-72088 Löhningen www.ews-tool.de</p>	<p>Technische Änderungen vorbehalten! Subject to technical modifications! IDENT: DEWS021953</p>	<p>REV: -/A 117678</p> 
--	---	--	---	---	---

Nr. - No. 40.3232SL200BMTIKD