

Spannzange / collet ER25 DIN6499
 Spannbereich / clamping range: 1,0 - 16,0

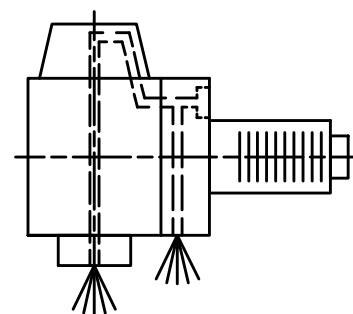

Innen- und Aussenkuehlung / Inside and outside coolant supply
 Kuehlmittelfiltrierung <math>< 50\mu</math> / coolant filtration <math>< 50\mu</math>

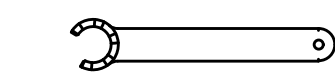
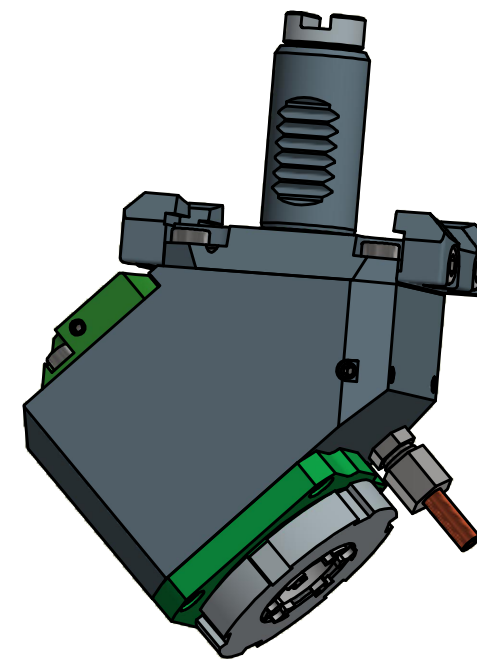

Spannzangenschlüssel für innenliegende Mutter
 Clamping wrench for internal collet
 225AX

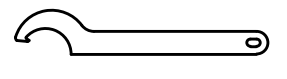

Hakenschlüssel mit Nase
 Hook wrench with nose end
 DIN1810 A 58x62

Copyright **EWS Tool Technologies**
 Weitergabe und Vervielfaeltigung dieser Unterlage, Verwertung und Mitteilung ihres Inhalts nicht gestattet, soweit nicht ausdrecklich zugestanden. Zuwiderhandlungen verpflichten zu Schadenersatz.

Bemerkung - Note
 Für Trockenlauf geeignet!
 Use without coolant fluid allowed!
 mit Kegelrollenlager
 with taper roller bearing(s)

Technische Daten - technical data	
Weight	= 3.385 [kg]
Torque max. (M1/M2)	= 20 / 40 [Nm]
Speed max. (n1/n2)	= 6000 / 3000 [1/min]
Gear ratio (i)=n1:n2	= 2:1
Pressure (pmax)	= 70 [bar]

Benennung - Title
Radial Bohr und Fräskopf
Radial drilling and milling head

EWS Tool Technologies
 EWS Weigle GmbH & Co. KG
 Maybachstr. 1
 D-73066 UHINGEN
 www.ews-tools.de

Technische Aenderungen vorbehalten! Subject to technical modifications!	IDENT: D-EWS-068232
Nr. - No.	MNR.
60.2525KRG200RIKDI2TKW45IM	144786

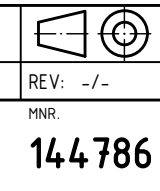

QR