

EWS-Varia V5

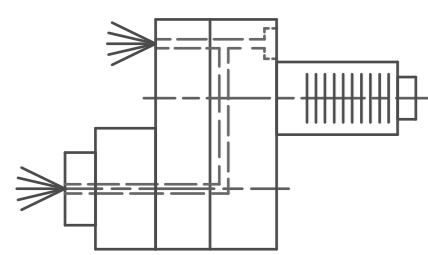
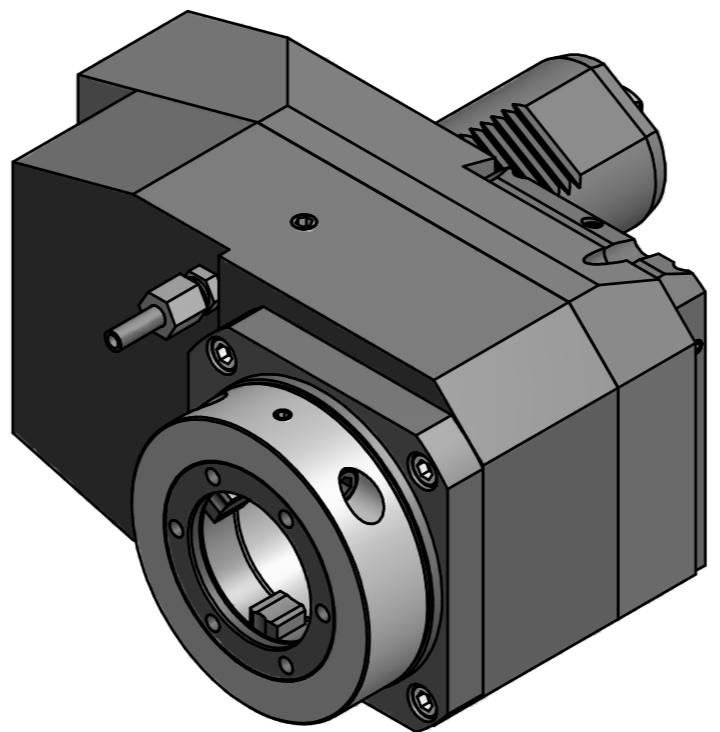
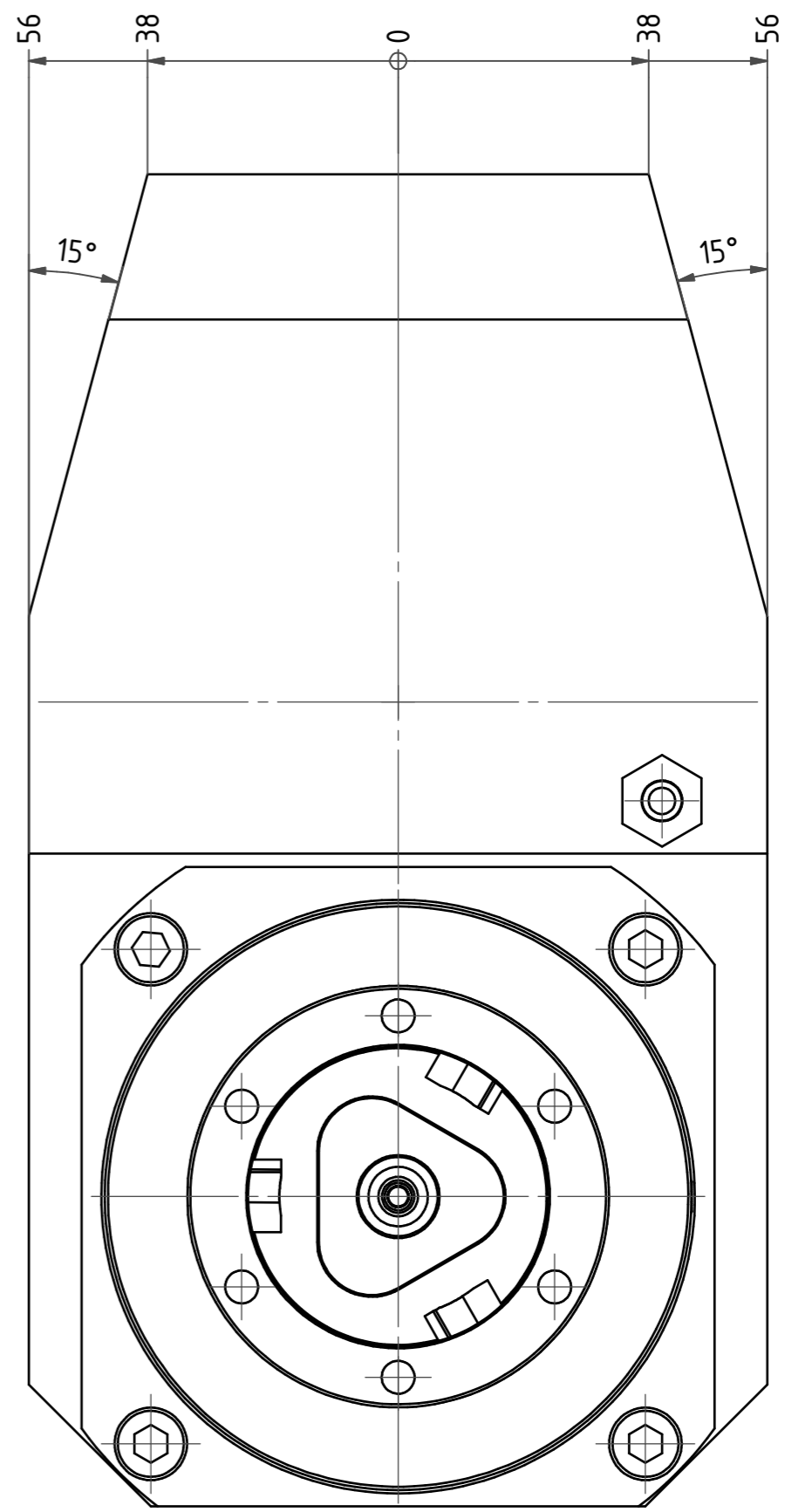

Innen- und Aussenkuehlung / Inside and outside coolant supply
 Kein Trockenlauf / No dry run
 Kuehlmittefiltrierung-50µ / coolant filtration-50µ

Bemerkung - Note Nicht ohne Kuehlmittel betreiben! Not for use without coolant-fluid!		Technische Daten - technical data M1 / M2 = 100 / 50 Nm n1 / n2 = 4000 / 8000 1/min i (N1:N2) = 1:2 Pmax = 70 bar		Benennung - Title Axial Bohr u. Fräskopf achsversetzt Ax. drill. and mill. head offset		name Rogler		date 14.05.2014		Technische Aenderungen vorbehalten! Subject to technical modifications!	
drawing						Nr. 50.50V5SQT28RIK11					
EWS Tool Technologies						EWS Weigle GmbH & Co. KG Maybachstr. 1 D-73065 Ultingen Tel. +49(0)716193040-100					
				MNR: 145046		IDENT: D-EWS-156111 -		Blatt - page 1 (1)			

Copyright **EWS Tool Technologies**
 Weitergabe und Vervielfaeltigung dieser Unterlage,
 Verwertung und Mitteilung ihres Inhalts nicht
 gestattet, soweit nicht ausdrecklich zugestanden.
 Zuwiderhandlungen verpflichten zu Schadenersatz.

