

Spannzange / collet ER40 DIN6499
 Spannbereich / clamping range: 3,0 - 26,0

Gewindebohrzange / tapping collet
 ET-1-40 M6-M16

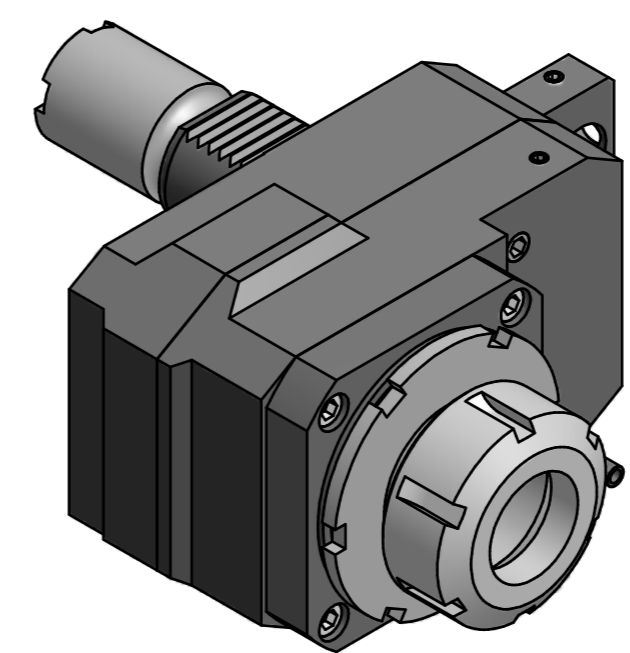
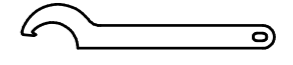
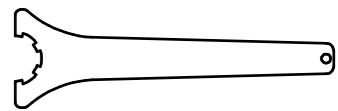

 Hakenschlüssel
 mit Nase
 Hook wrench with
 nose end
 DIN1810 A 80x90

 Spannzangenschlüssel
 Clamping wrench
 240

Copyright **EWS Tool Technologies**
 Weitergabe und Vervielfältigung dieser Unterlage,
 Verwertung und Mitteilung ihres Inhalts nicht
 gestattet, soweit nicht ausdrücklich zugestanden.
 Zuwiderhandlungen verpflichten zu Schadenersatz.

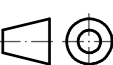
Bemerkung - Note	Technische Daten - technical data $M_1 / M_2 = 40 / 120 \text{ Nm}$ $n_1 / n_2 = 6000 / 2000 \text{ 1/min}$ $i (N_1:N_2) = 3:1$	Benennung - Title Axial Bohr u. Fräskopf achsversetzt <i>Ax. drill. and mill. head offset</i>	name	date	Technische Änderungen vorbehalten! <i>Subject to technical modifications!</i>	
			drawing	Theiss		
			EWS <small>EWS Werkzeug GmbH & Co. KG Maybachstr. 1 D-72096 Ulm/Donau Tel. +49(0)7161/93040-100</small>		Nr. 50.4040LB25LI3	DIN A2
			MNR: 139590		IDENT: D-EWS-156939 -	Blatt - page 1 (1)