

Spannzange / collet ER32 DIN6499  
 Spannbereich / clamping range: 2,0 - 20,0

max. 34,5  
 min. 31

6,5

0

85,5

98

103,5

128

116,5

96

90

53,5

17

0

117,55 ± 0,01

70

Ø40

Ø50

Ø50

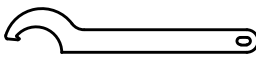
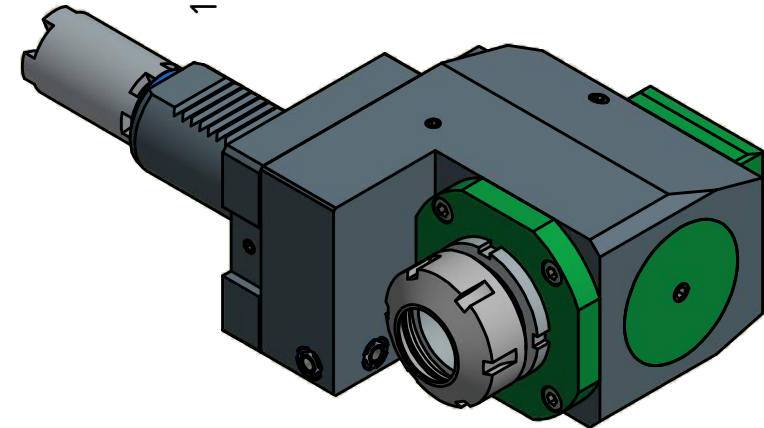
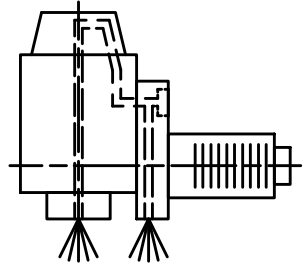
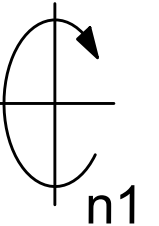
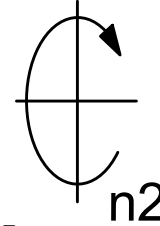

Hakenschlüssel  
 mit Nase  
 Hook wrench with  
 nose end  
 DIN1810 A 45x50

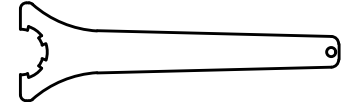

Spannzangenschlüssel  
 Clamping wrench  
 232

Innen- und Aussenkuehlung / Inside and outside coolant supply  
 Kuehlmittelfiltrierung-50µ / coolant filtration-50µ

Copyright **EWS Tool Technologies**  
 Weitergabe und Vervielfaeltigung dieser Unterlage,  
 Verwertung und Mitteilung ihres Inhalts nicht  
 gestattet, soweit nicht ausdrecklich zugestanden.  
 Zuwiderhandlungen verpflichten zu Schadenersatz.

Bemerkung - Note  
 Für Trockenlauf geeignet!  
 Use without coolant fluid allowed!

Technische Daten - technical data  
 Weight = 6.842 [kg]  
 Torque max. (M1/M2) = 50 / 50 [Nm]  
 Speed max. (n1/n2) = 6000 / 6000 [1/min]  
 Gear ratio (i)=n1:n2 = 1:1  
 Pressure (pmax) = 70 [bar]

Benennung - Title  
 Radial Bohr und Fräskopf, zurückges  
 Radial drill. and mill. head offset

**EWS** Tool Technologies  
 EWS Weigle GmbH & Co. KG  
 Maybachstr. 1  
 D-73066 UHINGEN  
 www.ews-tools.de  
 Nr. - No.  
 80.4032HAASSL40LIKD

Technische Aenderungen vorbehalten!  
 Subject to technical modifications!  
 IDENT: DEWS066236  
 REV: -/A  
 MNR.  
 139011

