

Fraeserwelle austaschbar  
Spindle removable

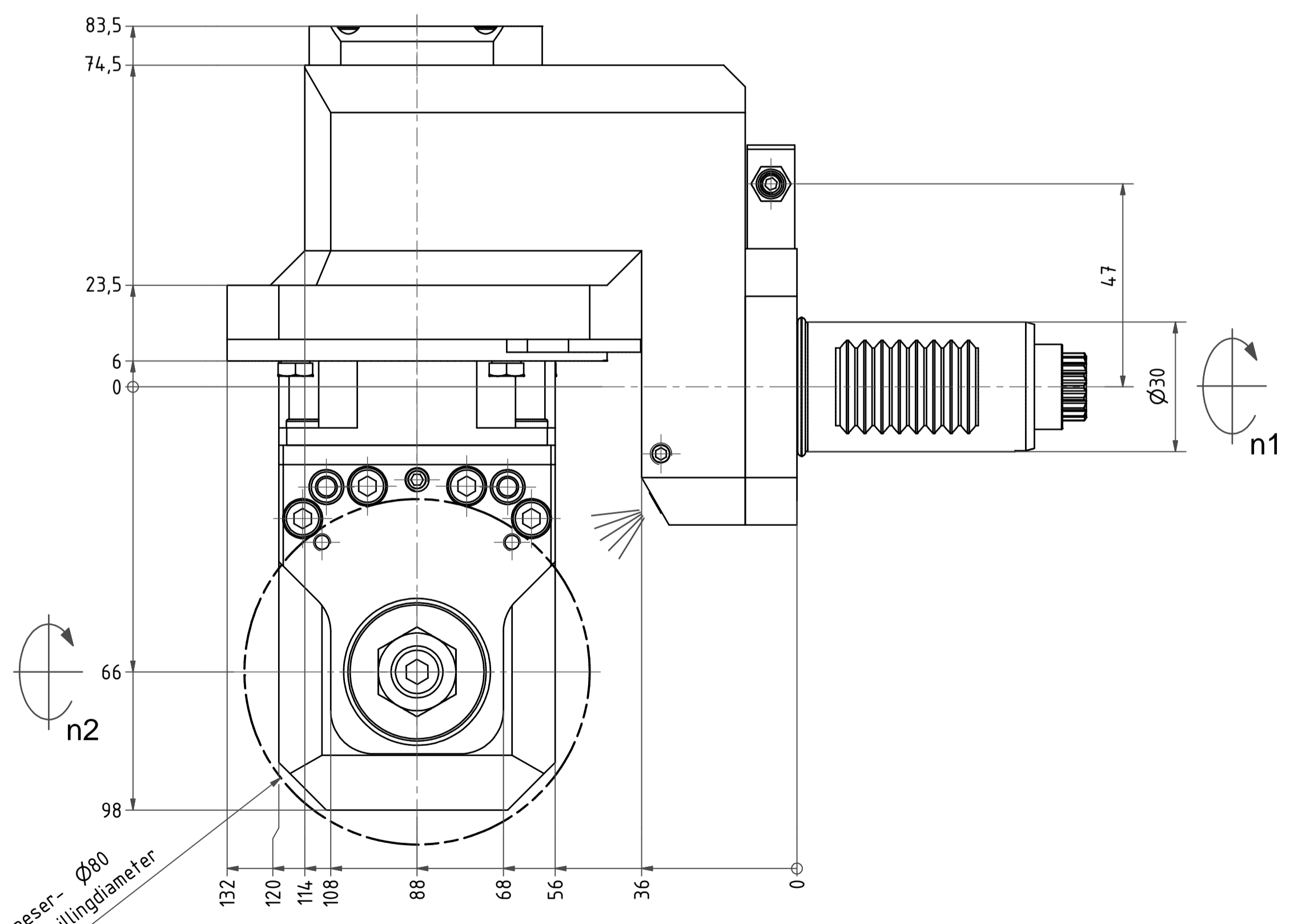

max. Fraeser - Ø80  
max. saw milling diameter

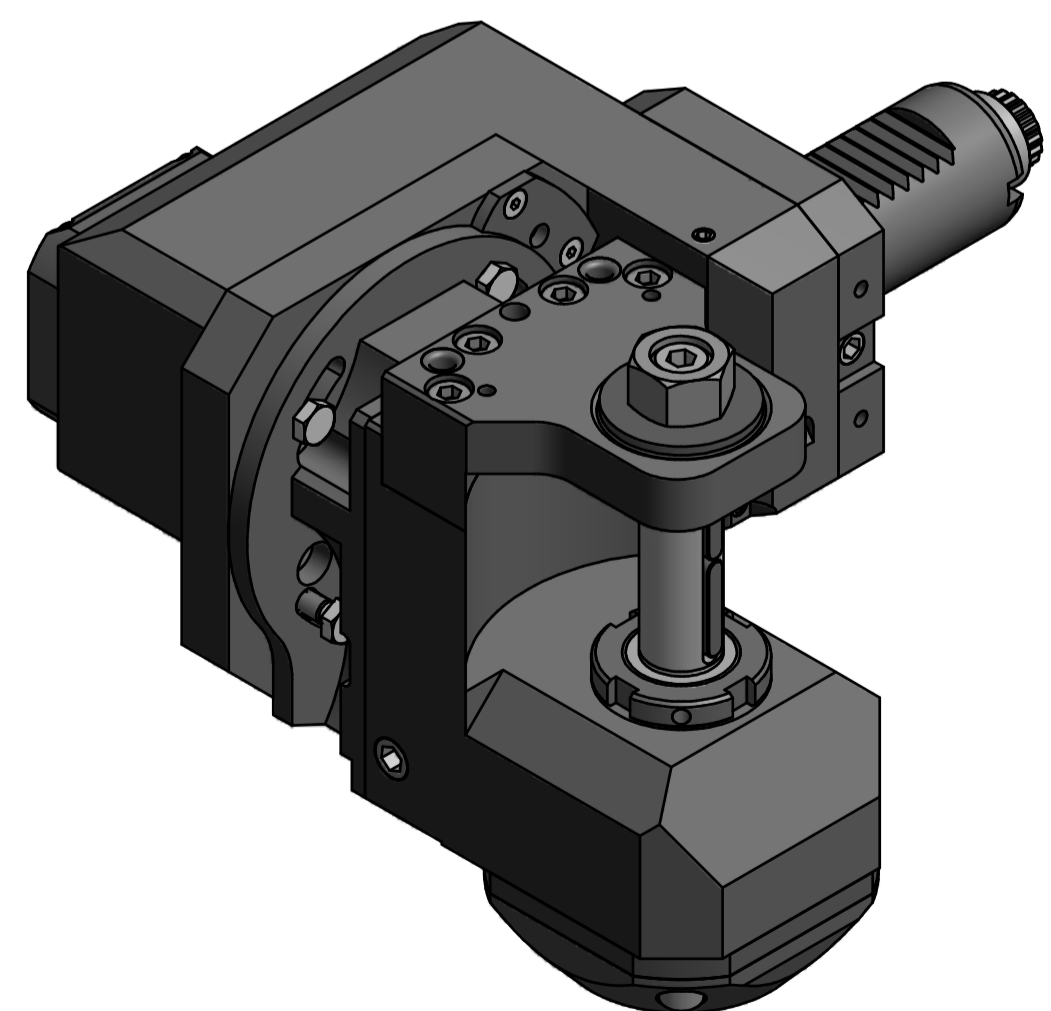
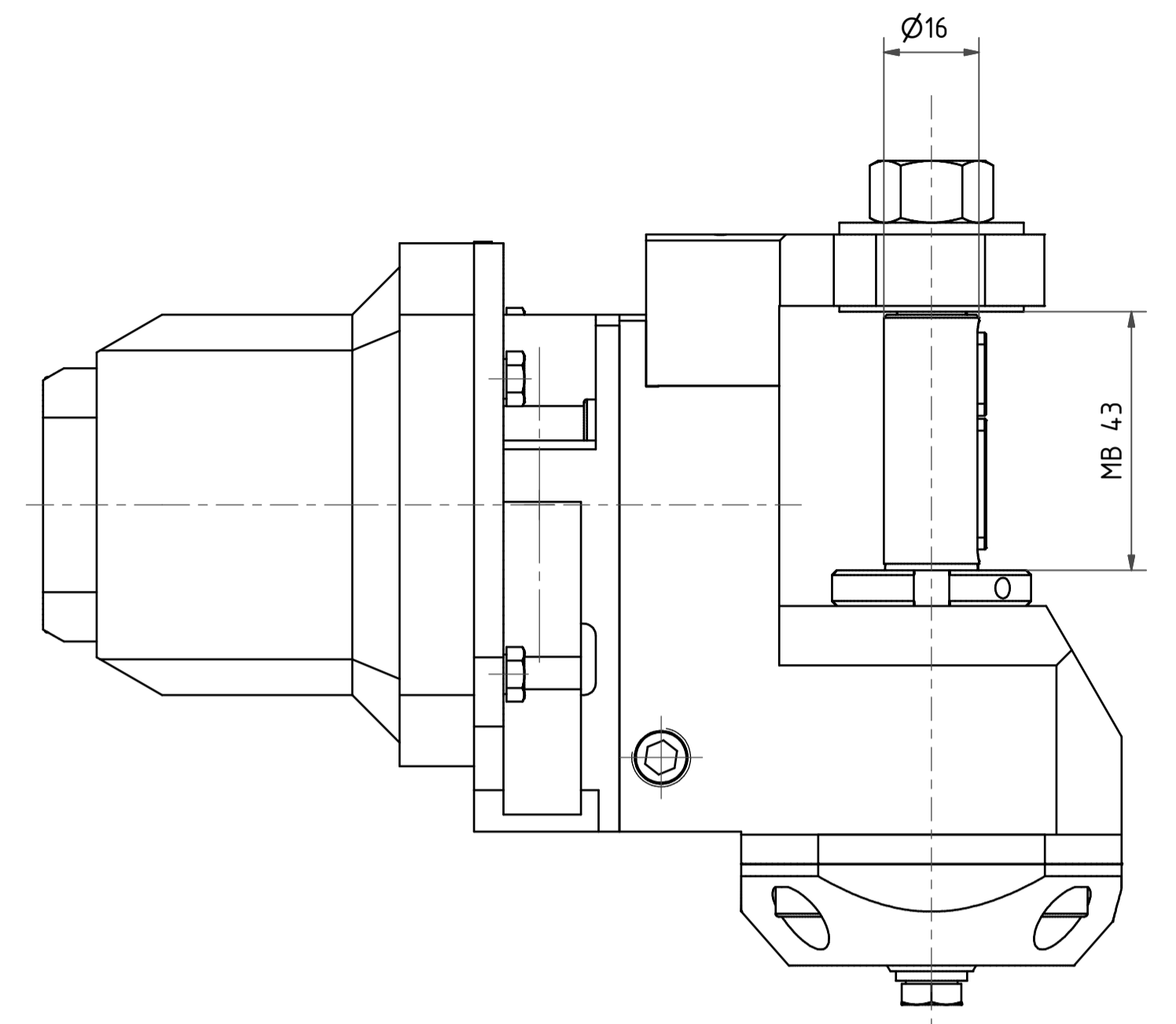
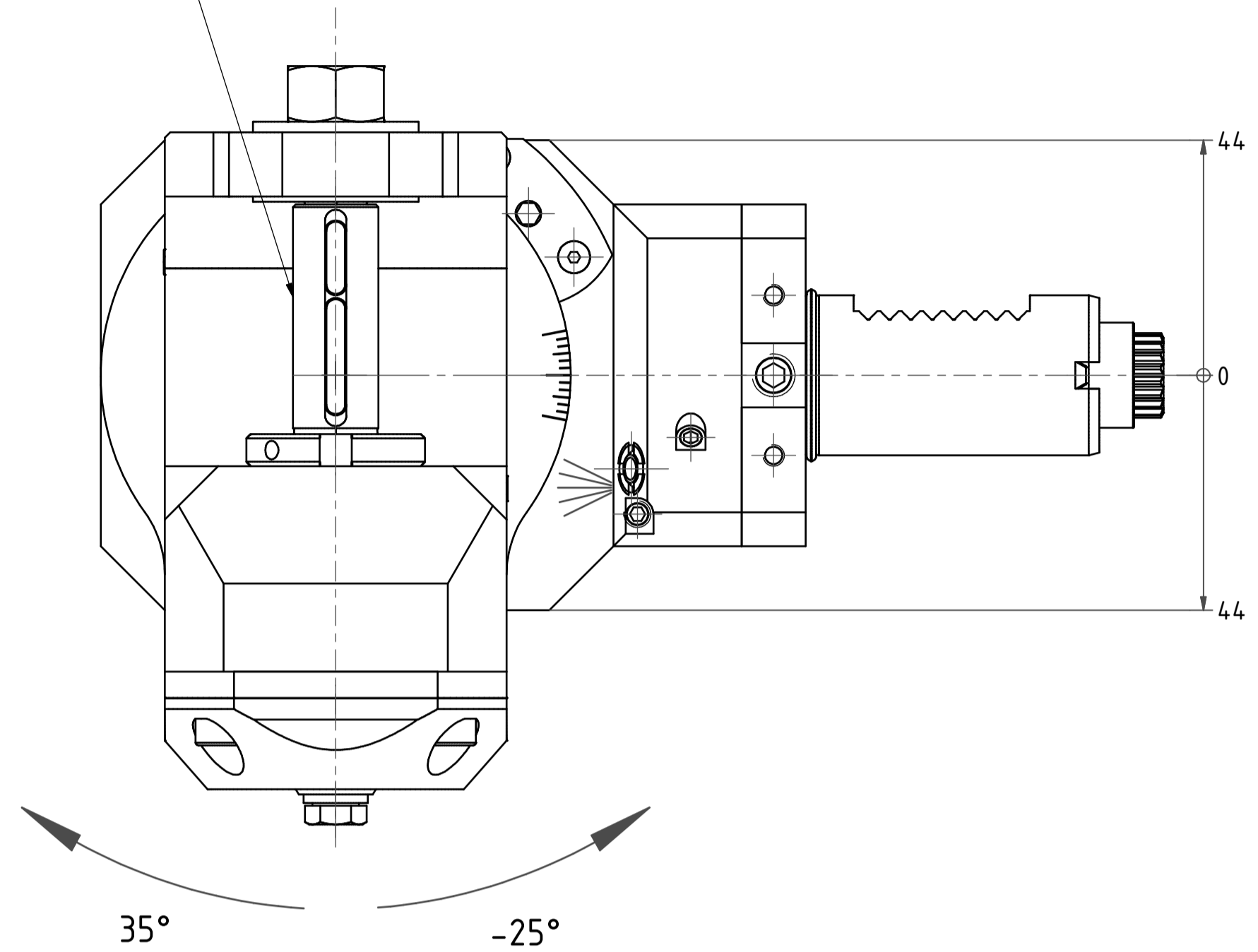
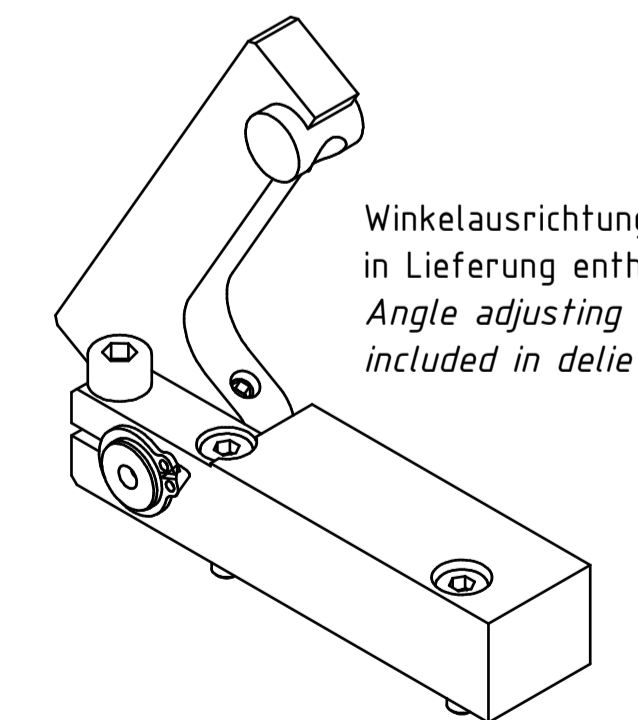

Winkelausrichtung & CD-ROM  
in Lieferung enthalten!  
Angle adjusting & CD-ROM  
included in delivery!

Copyright **EWS Tool Technologies**  
Weitergabe und Vervielfältigung dieser Unterlage  
Verwertung und Mitteilung ihres Inhalts nicht  
gestattet, soweit nicht ausdrücklich zugestanden.  
Zuwerhandlungen verpflichten zu Schadenersatz.

Bemerkung - Note	Technische Daten - Technical data M1 / M2 = 20 / 60 Nm n1 / n2 = 6000 / 2000 1/min i (N1:N2) = 3:1	Benennung - Title <b>Radial Scheibenfräserkopf versetzt</b> <b>Saw milling spindle offset</b>	name	date	Technische Änderungen vorbehalten! Subject to technical modifications!
			drawing	31.10.2012	
			<b>EWS</b> EWS Werkzeug GmbH & Co. KG Hauptstraße 7 D-75048 Ulmberg Tel. +49(0)71412044-100	84.3016CTX13TKWMB43	
			MNR: 137464	IDENT: D-EWS-121992	Blatt - page 1 (1 1)