

Spannzange / collet ER20 DIN6499  
 Spannbereich / clamping range: 1,0 - 13,0

Gewindebohrzange / tapping collet  
 ET-1-20 M2-M6

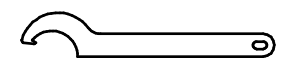
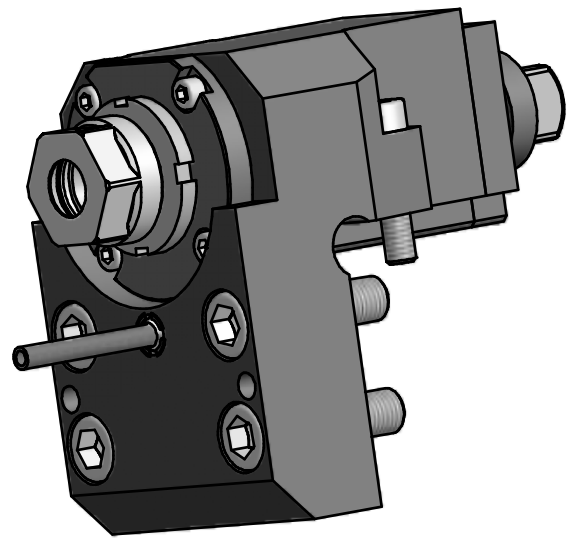

Hakenschlüssel  
 mit Nase  
 Hook wrench with  
 nose end  
 DIN1810 A 40x42

Copyright **EWS Tool Technologies**  
 Weitergabe und Vervielfaeltigung dieser Unterlage,  
 Verwertung und Mitteilung ihres Inhalts nicht  
 gestattet, soweit nicht ausdruuecklich zugestanden.  
 Zuwiderhandlungen verpflichten zu Schadenersatz.

Bemerkung - Note	Technische Daten - technical data M1 / M2 = 25 / 25 Nm n1 / n2 = 6000 / 6000 1/min i (N1:N2) = 1:1	Benennung - Title <b>Axial Bohr und Fräskopf</b> <i>Axial drilling and milling head</i>	<table border="1"> <tr> <th>name</th> <th>date</th> </tr> <tr> <td>Kratschmann</td> <td>24.07.2007</td> </tr> </table>	name	date	Kratschmann	24.07.2007	Technische Aenderungen vorbehalten! Subject to technical modifications! Nr. <b>40.3220SL150BMT</b>	 DIN A3
name	date								
Kratschmann	24.07.2007								
			Weigele GmbH & Co. KG Maybachstr. 1 D-73066 Uhingen Tel. +49(0)7161/93040-10	MNR: 117559 IDENT: D-EWS-048963 - Blatt - page 1 (1)					