

Spannzange / collet ER25 DIN6499  
 Spannereich / clamping range: 1,0 - 16,0

Gewindebohrzange / tapping collet  
 ET-1-25 M3-M10

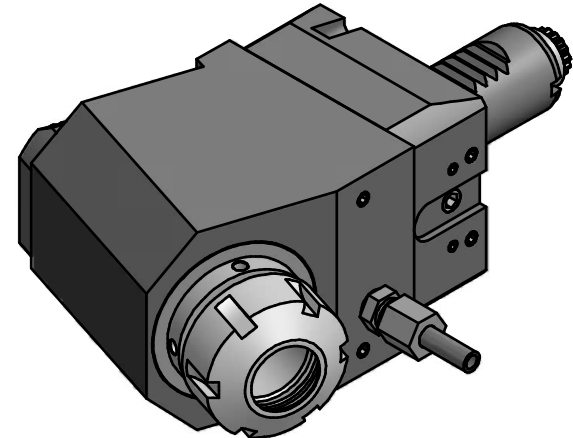
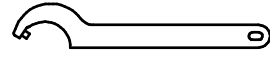
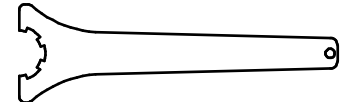

 Hakenschlüssel mit Zapfen  
 Hook wrench with fixed pin  
 DIN1810 B 40x42

 Spannzangenschlüssel  
 Clamping wrench  
 225

Copyright **EWS Tool Technologies**  
 Weitergabe und Vervielfaeltigung dieser Unterlage,  
 Verwertung und Mitteilung ihres Inhalts nicht  
 gestattet, soweit nicht ausdrecklich zugestanden.  
 Zuwiderhandlungen verpflichten zu Schadenersatz.

Bemerkung - Note	Technische Daten - technical data $M_1 / M_2 = 25 / 25 \text{ Nm}$ $n_1 / n_2 = 8000 / 8000 \text{ 1/min}$ $i (N_1:N_2) = 1:1$	Benennung - Title <b>Radial Bohr und Fräskopf</b> <i>Radial drilling and milling head</i>	<table border="1"> <tr> <th>name</th> <th>date</th> </tr> <tr> <td>Mühleisen</td> <td>30.10.2008</td> </tr> </table>	name	date	Mühleisen	30.10.2008	Technische Aenderungen vorbehalten! Subject to technical modifications! Nr. <b>60.25255480RTKW72</b>	 DIN A3
name	date								
Mühleisen	30.10.2008								
			 EWS Weigle GmbH & Co. KG Maybachstr. 1 D-73066 Uhingen Tel. +49(0)7161/93040-100	MNR: 144705 IDENT: D-EWS-067961 A Blatt - page 1 (1)					