

6 5 4 3 2 1

D  
C  
B  
A

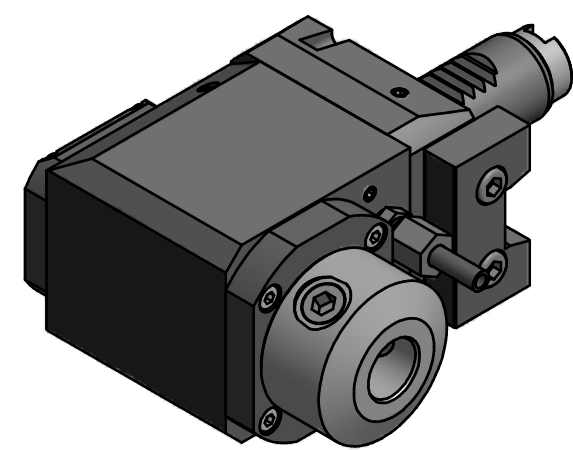
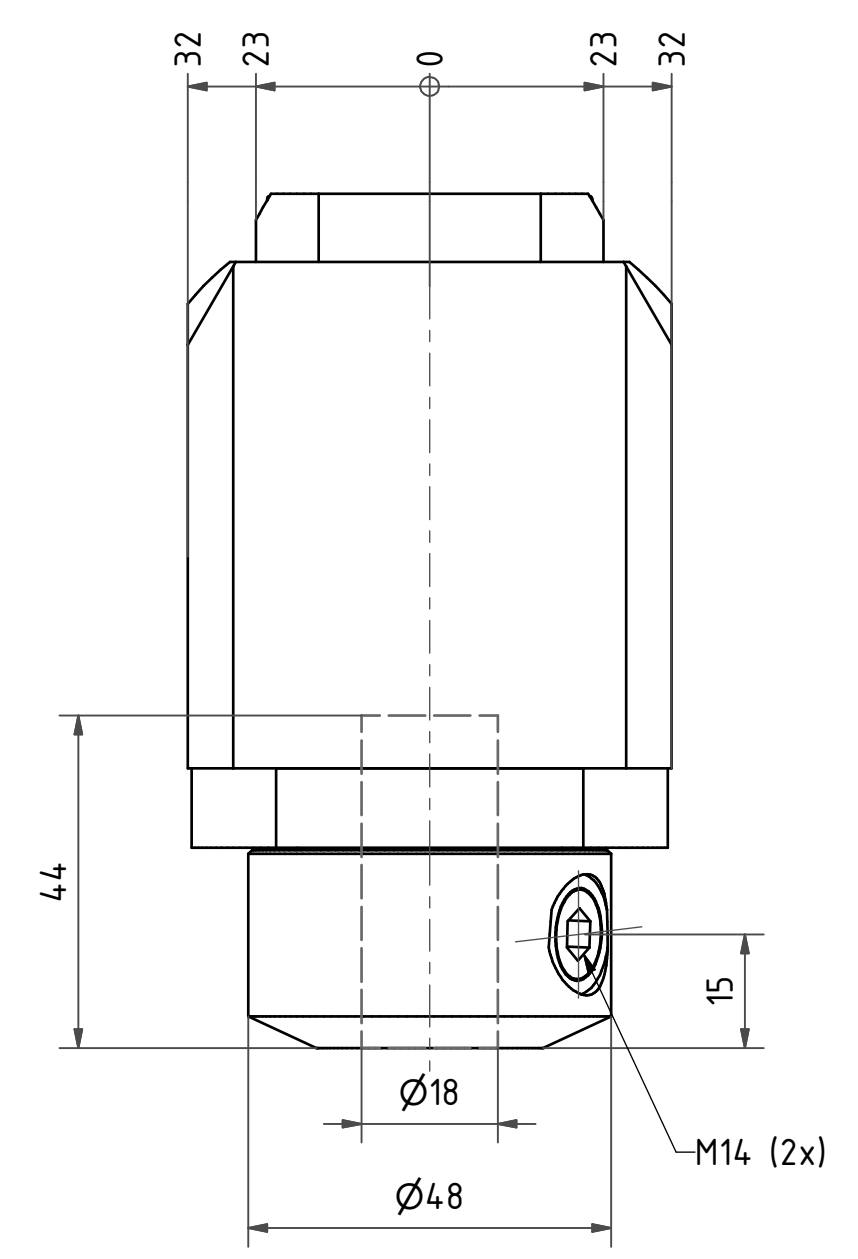
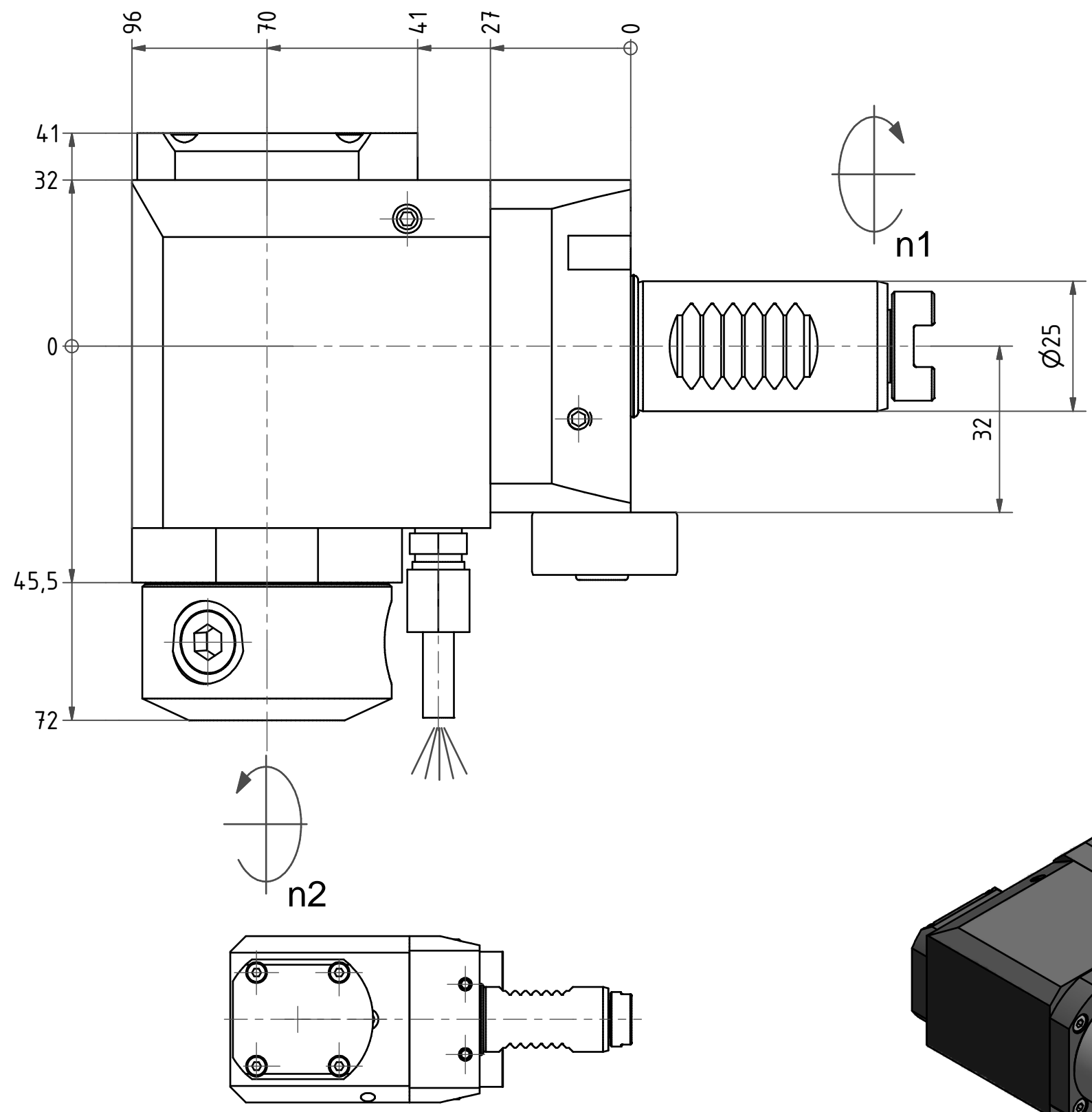

Doppelverzahnung Lizenz Traub  
double tooth system licence Traub

Copyright **EWS Tool Technologies**  
Weitergabe und Vervielfaeltigung dieser Unterlage,  
Verwertung und Mitteilung ihres Inhalts nicht  
gestattet, soweit nicht ausdrecklich zugestanden.  
Zuwiderhandlungen verpflichten zu Schadenersatz.

Bemerkung - Note	Technische Daten - technical data M1 / M2 = 25 / 25 Nm n1 / n2 = 8000 / 8000 1/min i (N1:N2) = 1:1	Benennung - Title <b>Radial Bohr und Fräskopf</b> <i>Radial drilling and milling head</i>	name	date	Technische Aenderungen vorbehalten! Subject to technical modifications!	
			drawing	M. Simoniello		
					Nr. <b>60.2518WNG200RLV</b>	DIN A3
			EWS Weigete GmbH & Co. KG Maybachstr. 1 D-73066 Uhingen Tel. +49(0)7161/93040-100			
			MNR: 117316		IDENT: D-EWS-186552 -	Blatt - page 1 (1)

6 5 4 3 2 1