

Spannzange / collet ER25 DIN6499
Spannbereich / clamping range: 1,0 - 16,0

Gewindebohrzange / tapping collet
ET-1-25 M3-M10

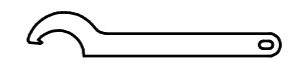

Hakenschlüssel
mit Nase
Hook wrench with
nose end
DIN1810 A 45x50

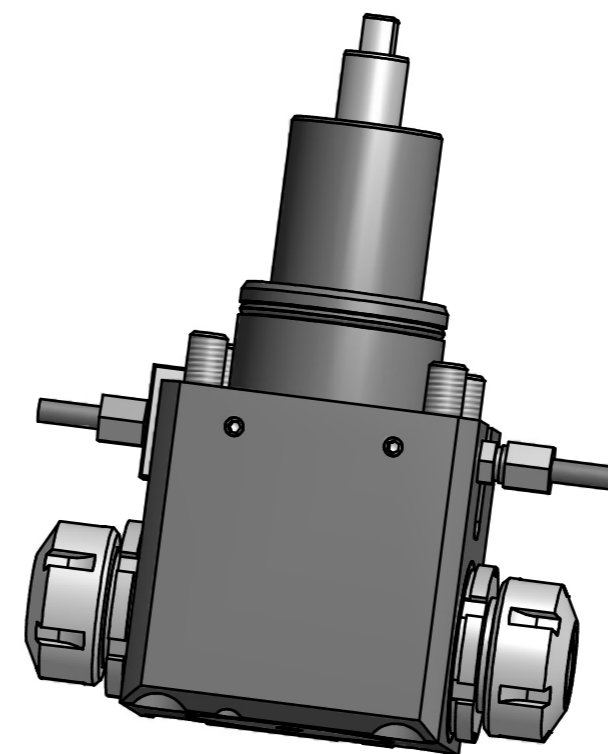
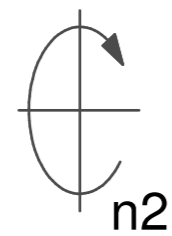
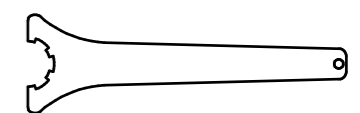

Spannzangenschlüssel
Clamping wrench
225

Copyright **EWS Tool Technologies**
Weitergabe und Vervielfältigung dieser Unterlage,
Verwertung und Mitteilung ihres Inhalts nicht
gestattet, soweit nicht ausdrücklich zugestanden.
Zuwendungen verpflichten zu Schadenersatz.

Bemerkung - Note

Technische Daten - technical data

Weight = 5.393 [kg]
Torque max. (M1/M2) = 25 / 25 each Sp. [Nm]
Speed max. (n1/n2) = 6000 / 6000 [1/min]
Gear ratio (i)=n1:n2= 1:1

Benennung - Title

Radial Bohr und Fräskopf
Radial drilling and milling head



Nr. - No.
60.5525D1809

Technische Änderungen vorbehalten!
Subject to technical modifications!
IDENT: D-EWS-001209

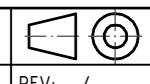

REV: -/-
MNR.
124062

