

Spannzange / collet ER50 DIN6499
 Spannbereich / clamping range: 6,0 - 34,0

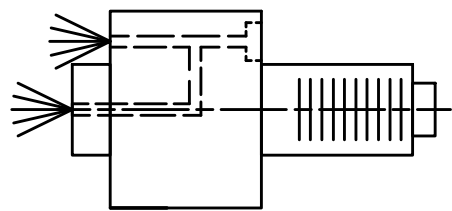

Innen- und Aussenkuehlung / Inside and outside coolant supply
 Kein Trockenlauf / No dry run
 Kuehlmittelfiltrierung 50μ / coolant filtration 50μ

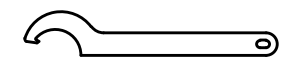
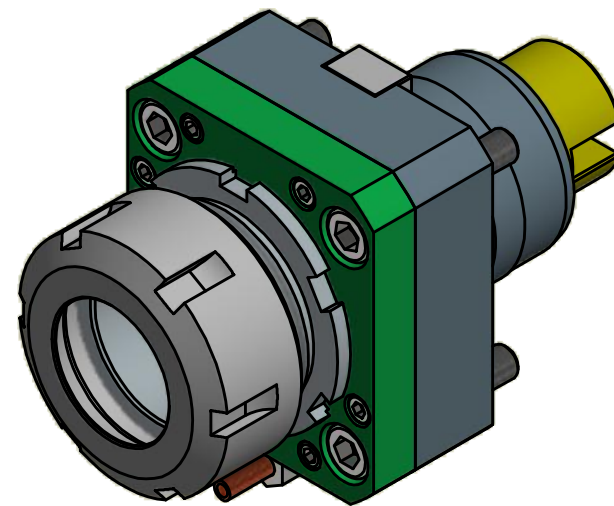

Hakenschlüssel
 mit Nase
 Hook wrench with
 nose end
 DIN1810 A 68x75

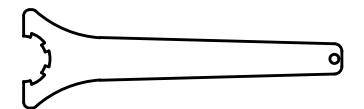

Spannzangenschlüssel
 Clamping wrench
 250

Copyright **EWS Tool Technologies**
 Weitergabe und Vervielfaeltigung dieser Unterlage,
 Verwertung und Mitteilung ihres Inhalts nicht
 gestattet, soweit nicht ausdrecklich zugestanden.
 Zuwiderhandlungen verpflichten zu Schadenersatz.

Bemerkung - Note
 Nicht ohne Kuehlmittel betreiben!
 Not for use without coolant-fluid!

Technische Daten - technical data
 Weight = 4.842 [kg]
 Torque max. (M1/M2) = 160 / 160 [Nm]
 Speed max. (n1/n2) = 3000 / 3000 [1/min]
 Gear ratio (i)=n1:n2 = 1:1
 Pressure (pmax) = 25 [bar]

Benennung - Title
 Axial Bohr und Fräskopf
 Axial drilling and milling head



Nr. - No.
 40.6050EX508BMTIK

Technische Aenderungen vorbehalten!
 Subject to technical modifications!
 IDENT: DEWS083405

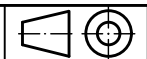

REV: -/A

MNR.
 150820

