

Spannzange / collet ER20 DIN6499  
 Spannbereich / clamping range: 1,0 - 13,0

Gewindebohrzange / tapping collet  
 ET-1-20 M2-M6

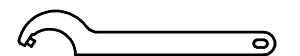
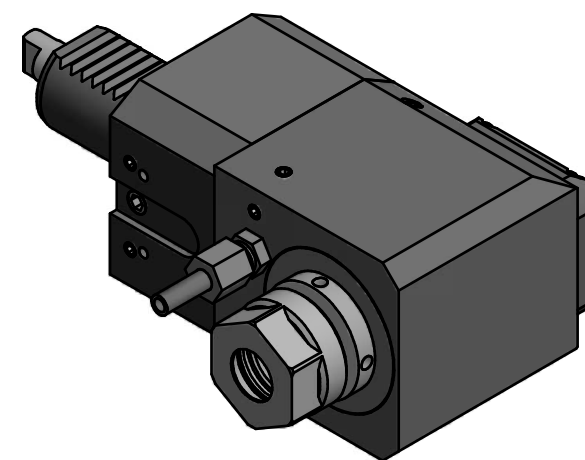
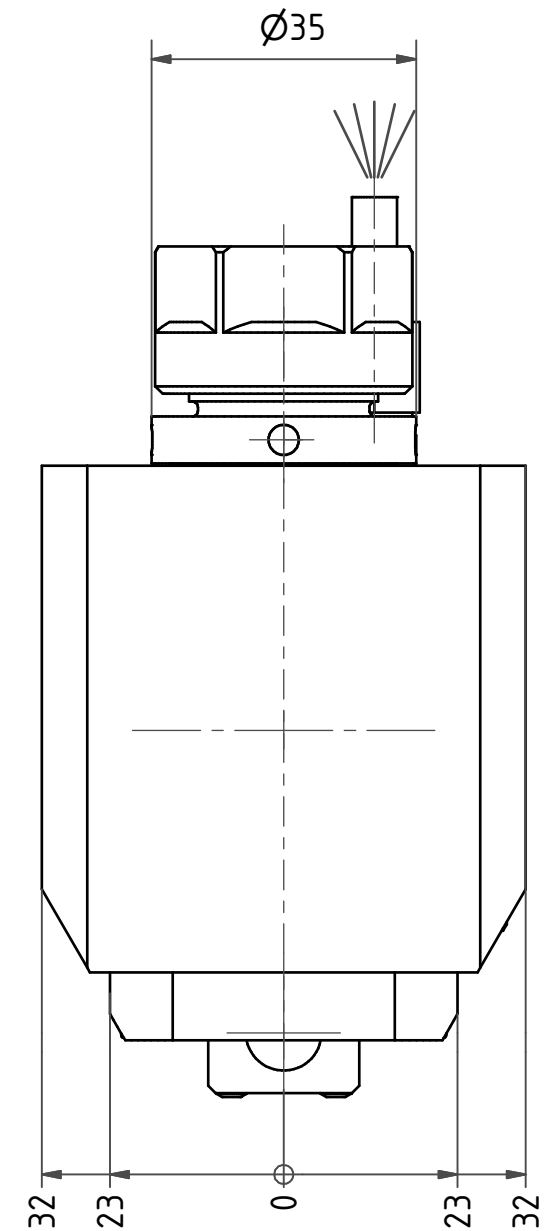

Hakenschlüssel  
 mit Zapfen  
 Hook wrench  
 with fixed pin  
 DIN1810 B 34x36

Copyright **EWS Tool Technologies**  
 Weitergabe und Vervielfaeltigung dieser Unterlage,  
 Verwertung und Mitteilung ihres Inhalts nicht  
 gestattet, soweit nicht ausdruuecklich zugestanden.  
 Zuwiderhandlungen verpflichten zu Schadenersatz.

Bemerkung - Note

Technische Daten - technical data

Benennung - Title

Weight = 3.530 [kg]  
 Torque max. (M1/M2) = 25 / 25 [Nm]  
 Speed max. (n1/n2) = 8000 / 8000 [1/min]  
 Gear ratio (i)=n1:n2 = 1:1

Radial Bohr und Fräskopf  
 Radial drilling and milling head

**EWS**  
 Tool Technologies

EWS Weigle GmbH & Co. KG  
 Maybachstr. 1  
 D-73066 Uhingen  
 www.ews-tools.de

Technische Aenderungen vorbehalten!  
 Subject to technical modifications!

IDENT: D-EWS-159728



REV: A/-

Nr. - No.

60.30201809LGLX85

MNR.

151246

