

EWS-Varia V5

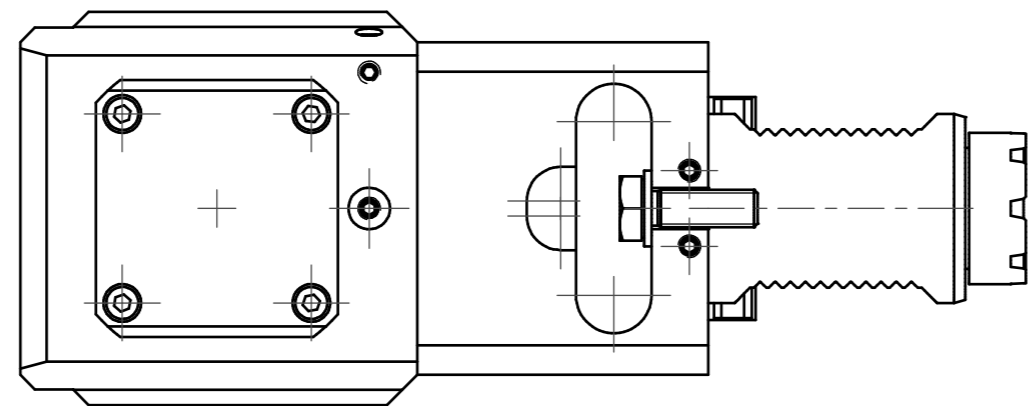

Doppelverzahnung Lizenz Traub
double tooth system licence Traub

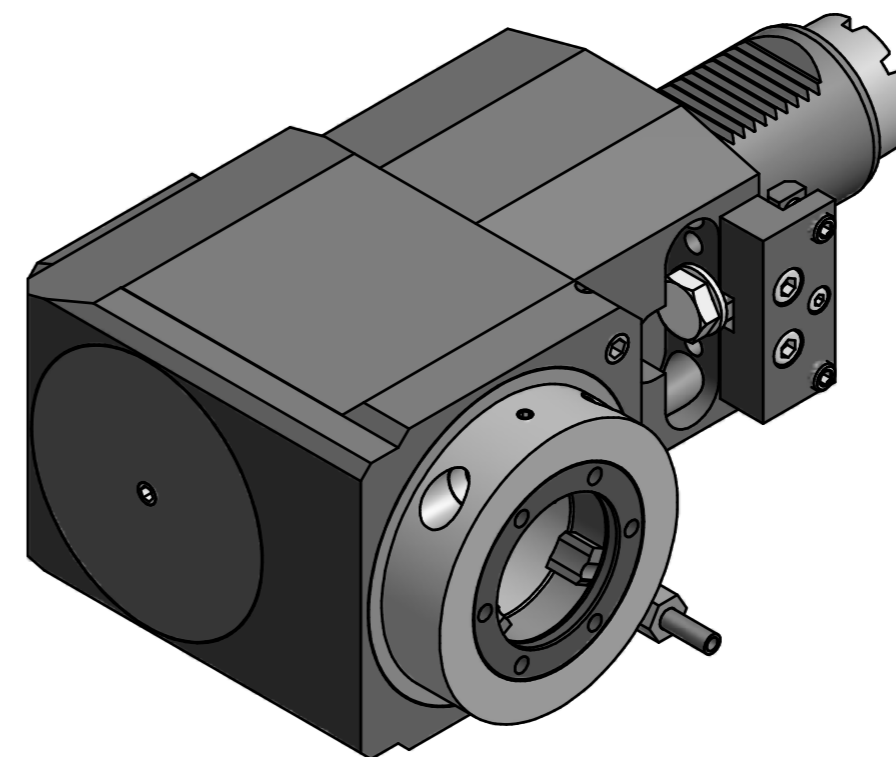

Copyright **EWS Tool Technologies**
Weitergabe und Vervielfältigung dieser Unterlage,
Verwertung und Mitteilung ihres Inhalts nicht
gestattet, soweit nicht ausdrücklich zugestanden.
Zuwendungen verpflichten zu Schadenersatz.

Bemerkung - Note	Technische Daten - Technical data		Benennung - Title	name Theiss date 03.09.2014 Technische Änderungen vorbehalten! Subject to technical modifications! Nr. 60.50V5TOEMRL1X130 MNR: 145073 IDENT: D-EWS-162369 - Blatt - page 1 (1)
	M ₁ / M ₂ = 100 / 50 Nm n ₁ / n ₂ = 4 000 / 8000 1/min i (N ₁ :N ₂) = 1:2			

