

Spannzange / collet ER40 DIN6499
 Spannbereich / clamping range: 3,0 - 26,0

Gewindebohrzange / tapping collet
 ET-1-40 M6-M16

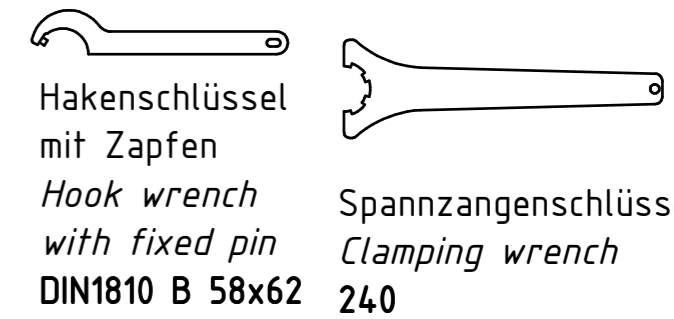
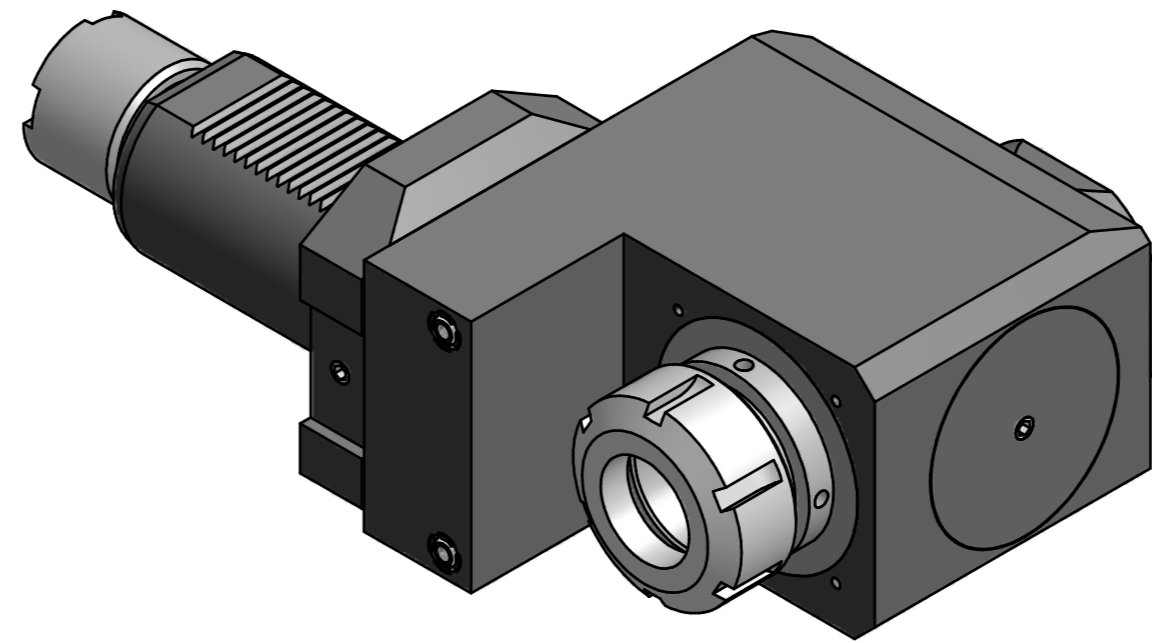
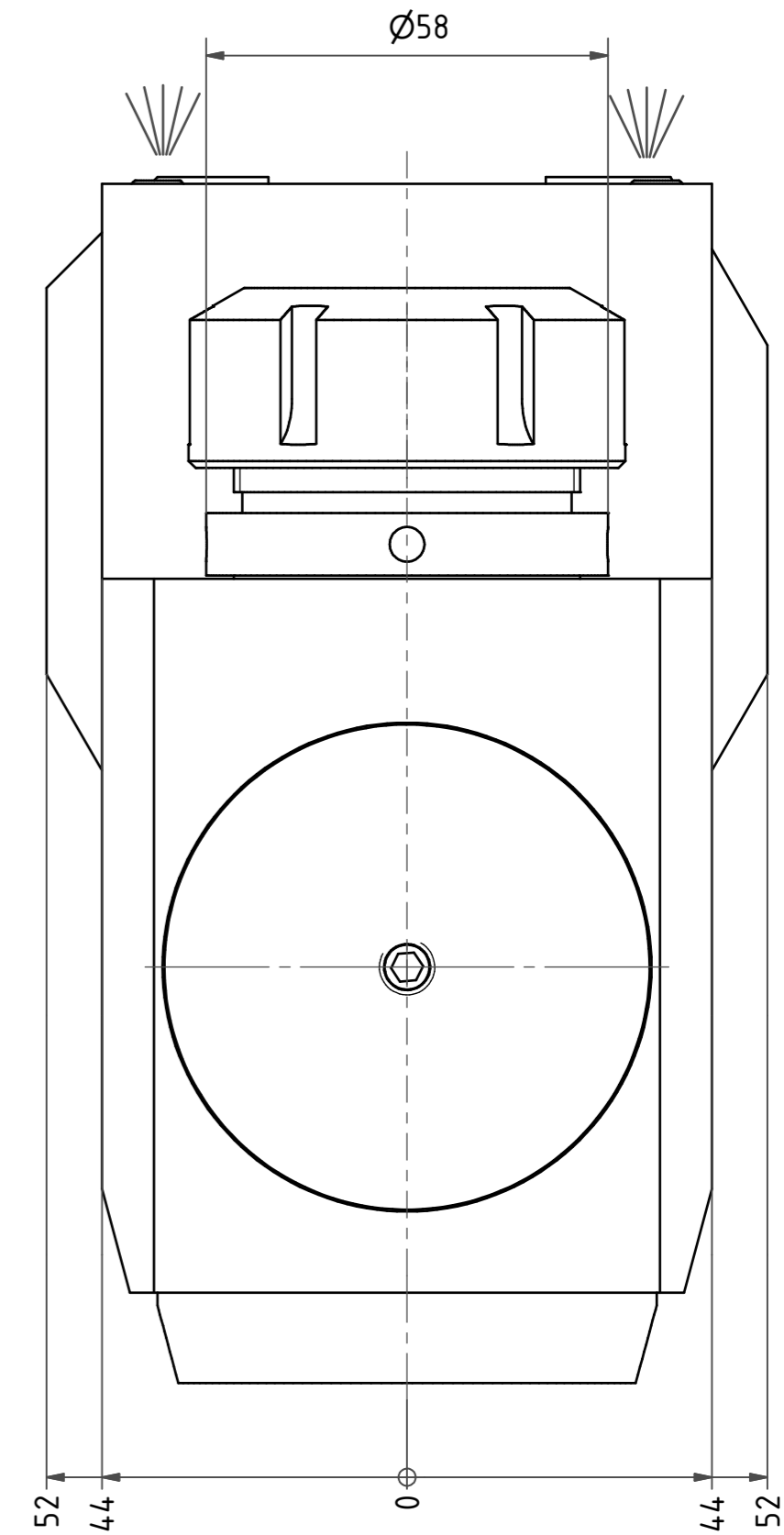
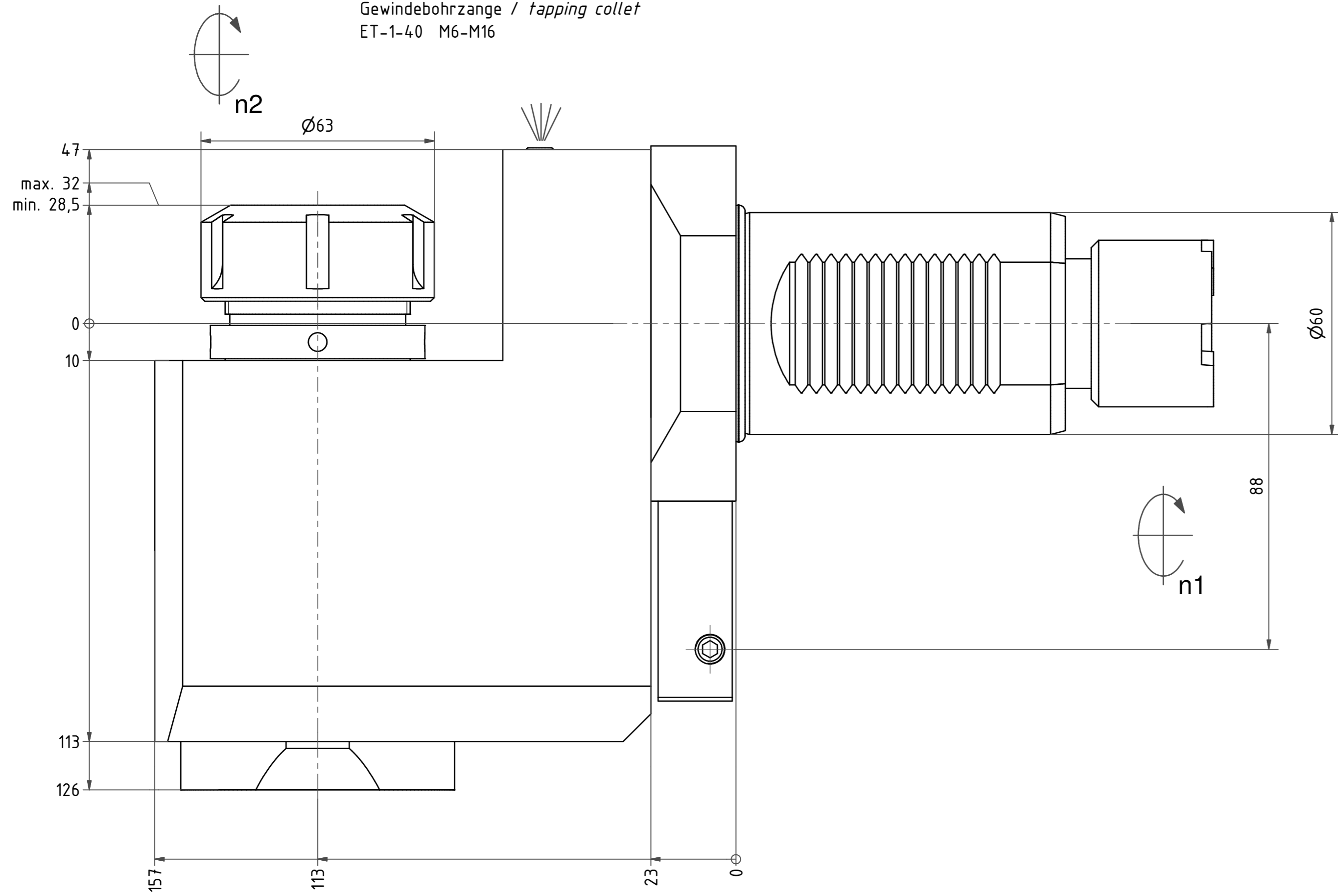

Hakenschlüssel
 mit Zapfen
 Hook wrench
 with fixed pin
 DIN1810 B 58x62

Spannzangenschlüssel
 Clamping wrench
 240

Copyright **EWS Tool Technologies**
 Weitergabe und Vervielfältigung dieser Unterlage,
 Verwertung und Mitteilung ihres Inhalts nicht
 gestattet, soweit nicht ausdrücklich zugestanden.
 Zuwiderhandlungen verpflichten zu Schadenersatz.

Bemerkung - Note	Technische Daten - technical data $M_1 / M_2 = 100 / 100 \text{ Nm}$ $n_1 / n_2 = 4000 / 4000 \text{ 1/min}$ $i (N_1:N_2) = 1:1$	Benennung - Title Radial Bohr und Fräskopf. zurückges <i>Radial drill. and mill. head offset</i>	name	date	Technische Änderungen vorbehalten! <i>Subject to technical modifications!</i>	DIN A2	
			drawing	Theiss			02.10.2014
			EWS Weigte GmbH & Co. KG Maybachstr. 1 D-72096 Ulm/lingen Tel. +49(0)7161/93040-100		Nr. 80.6040LB45L-BG50		Blatt - page 1 (1)
			MNR: 137975		IDENT: D-EWS-164383 -		