

6 | 5 | 4 | 3 | 2 | 1

D
C
B
A

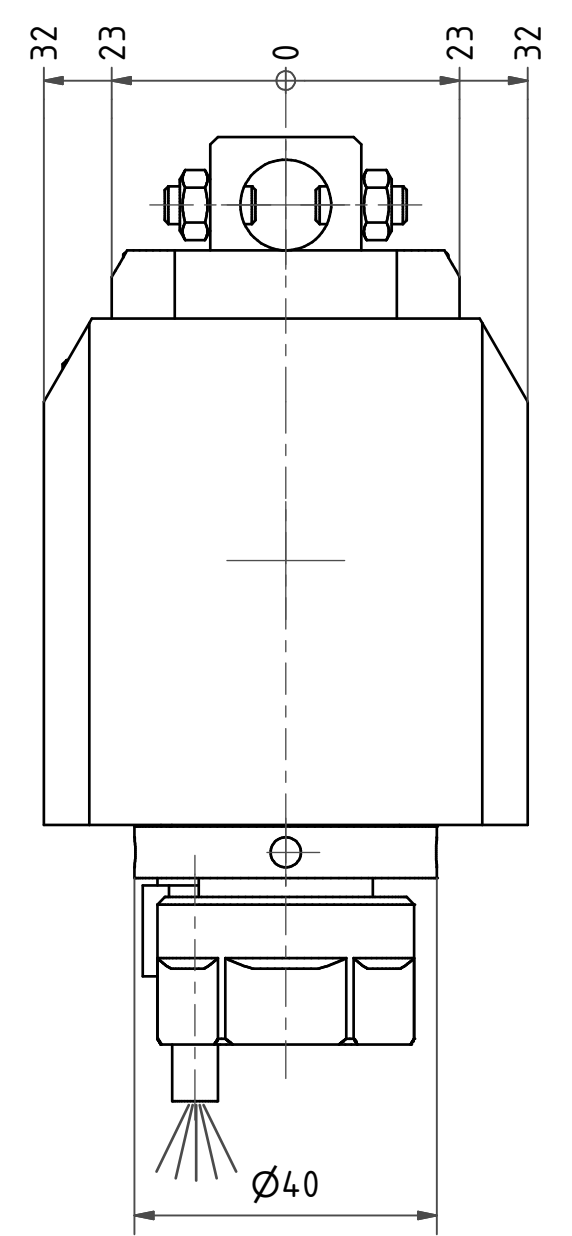
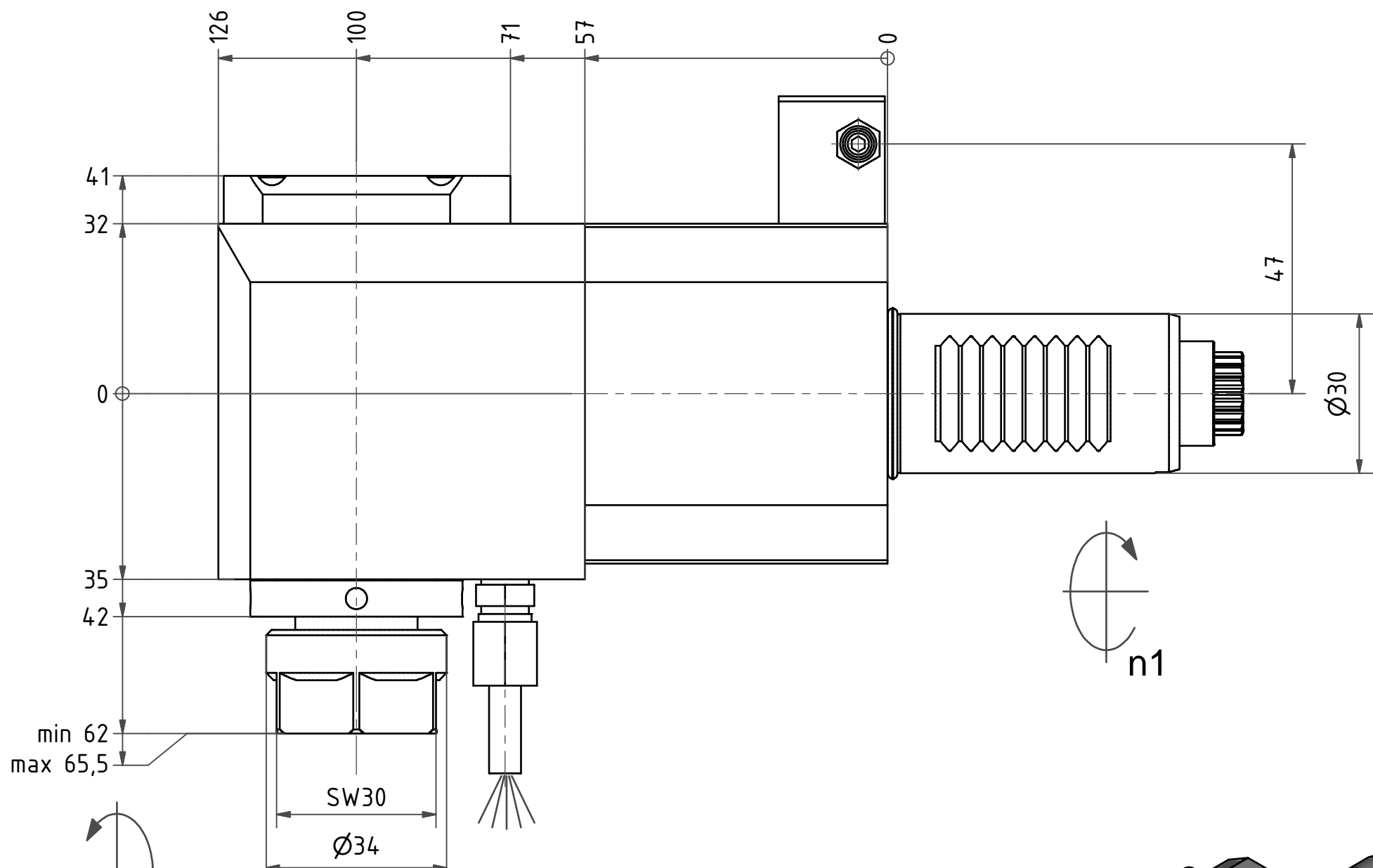

Spannzange / collet ER20 DIN6499
Spannbereich / clamping range: 1,0 - 13,0

Gewindebohrzange / tapping collet
ET-1-20 M2-M6

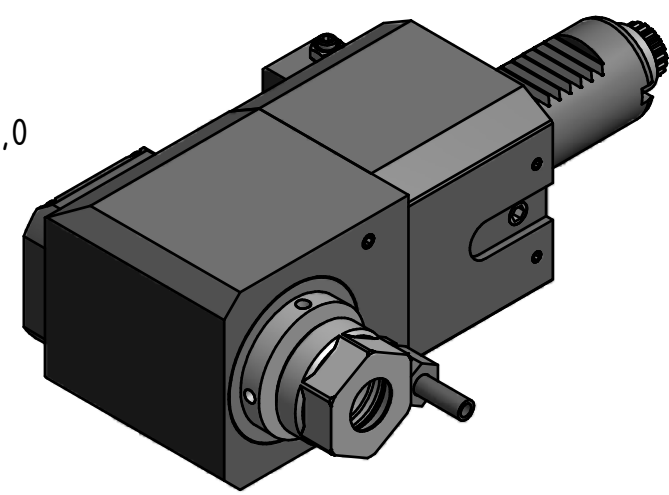

Hakenschlüssel
mit Zapfen
Hook wrench
with fixed pin
DIN1810 B 40x42

Copyright **EWS Tool Technologies**
Weitergabe und Vervielfältigung dieser Unterlage,
Verwertung und Mitteilung ihres Inhalts nicht
gestattet, soweit nicht ausdrücklich zugestanden.
Zuwendungen verpflichten zu Schadenersatz.

<p>Bemerkung - Note</p>	<p>Technische Daten - technical data M1 / M2 = 25 / 25 Nm n1 / n2 = 8000 / 8000 1/min i (N1:N2) = 1:1</p>	<p>Benennung - Title Radial Bohr und Fräskopf <i>Radial drilling and milling head</i></p>	<table border="1"> <tr> <th>name</th> <th>date</th> </tr> <tr> <td>M. Simoniello</td> <td>22.09.2015</td> </tr> </table> <p>EWS EWS Weigete GmbH & Co. KG Maybachstr. 1 D-73066 Uhingen Tel. +49(0)7161/93040-100</p>	name	date	M. Simoniello	22.09.2015	<p>Technische Änderungen vorbehalten! Subject to technical modifications!</p> <p>Nr. 60.3020LCTXR</p> <p>MNR: 116290 IDENT: D-EWS-186793 - Blatt - page 1 (1)</p>
name	date							
M. Simoniello	22.09.2015							

6 | 5 | 4 | 3 | 2 | 1