

Fraeserwelle austauschbar
Spindle removable

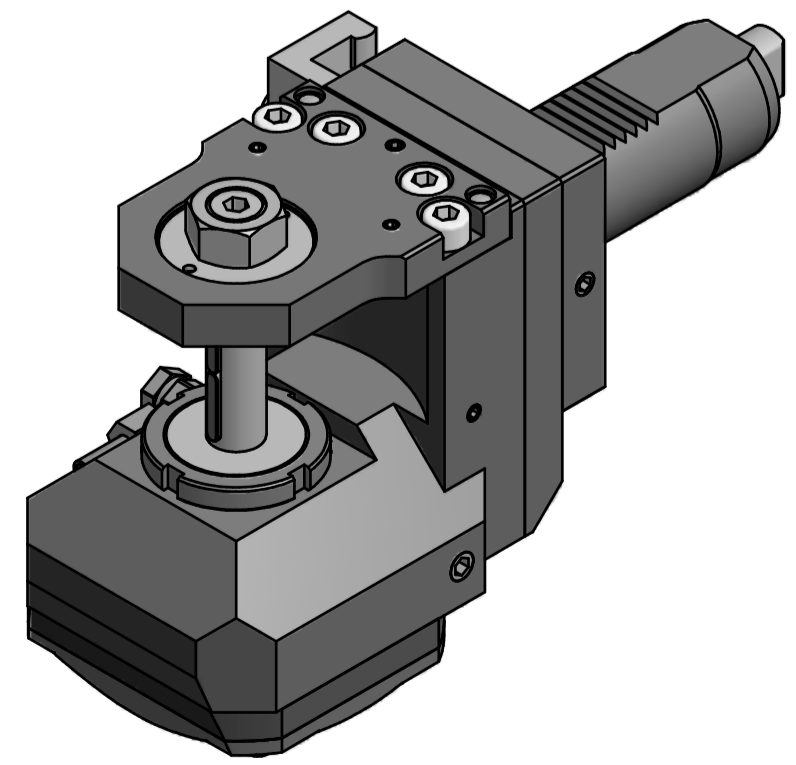
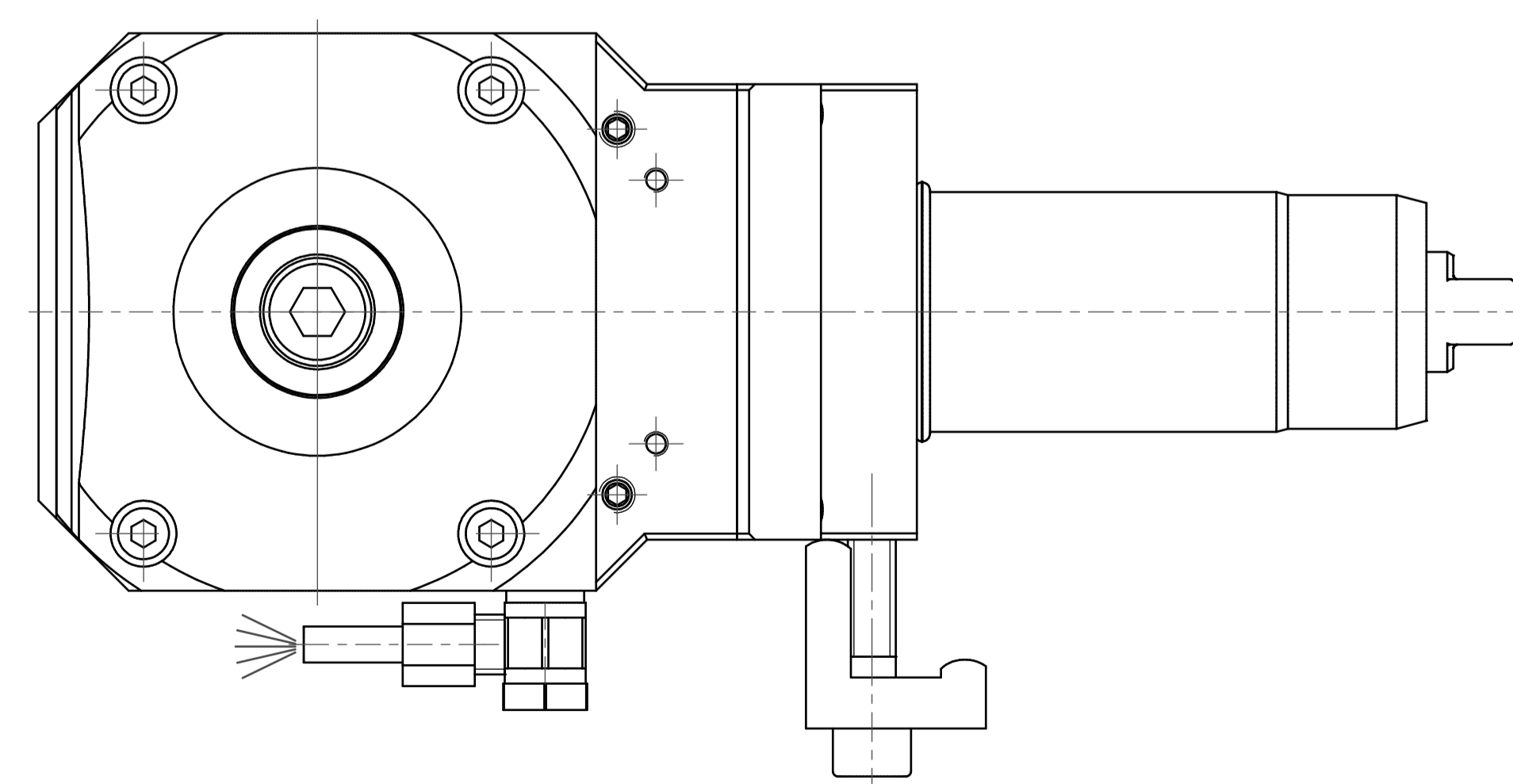
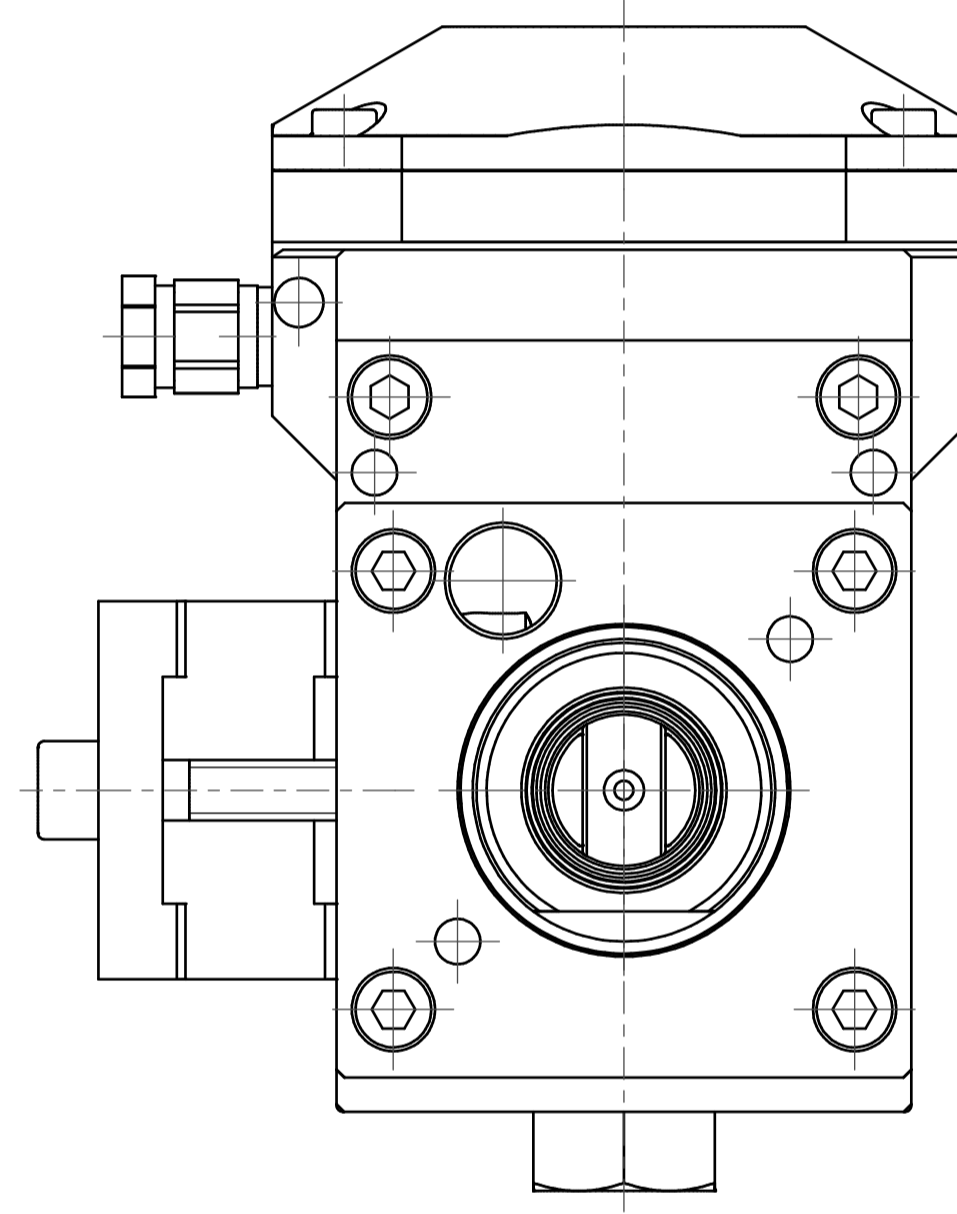
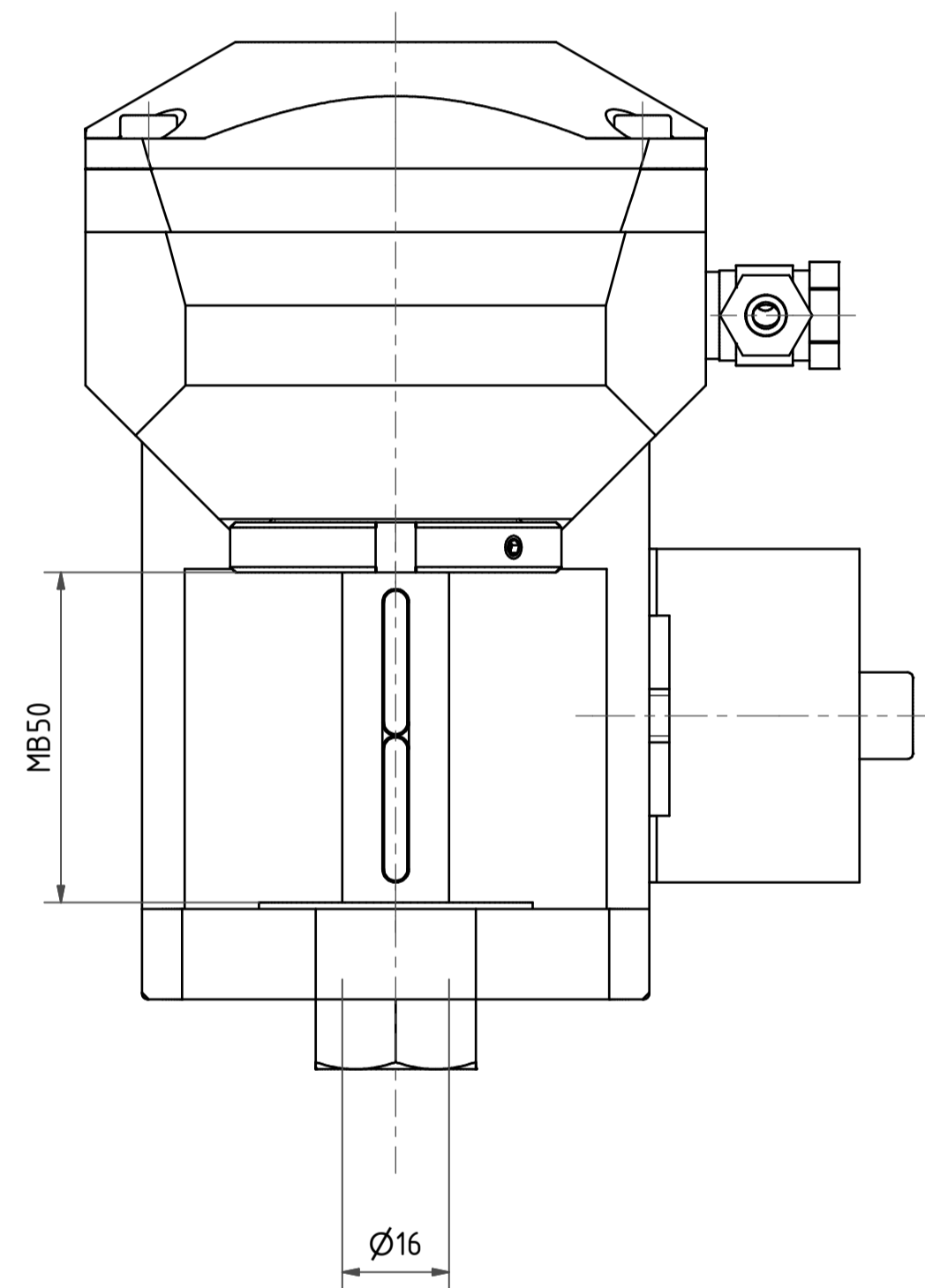

Copyright **EWS Tool Technologies**
Weitergabe und Vervielfältigung dieser Unterlage,
Verwertung und Mitteilung ihres Inhalts nicht
gestattet, soweit nicht ausdrücklich zugestanden.
Zuwerhandlungen verpflichten zu Schadenersatz.

Bemerkung - Note	Technische Daten - Technical data		Bezeichnung - Title		name	date	Technische Änderungen vorbehalten!	
	M1 / M2 = 50 / 150 Nm n1 / n2 = 6000 / 2000 1/min i (N1:N2) = 3:1		Scheibenfräserkopf <i>Radial saw milling head</i>				Subject to technical modifications!	
					EWS EWS Werkzeug GmbH & Co. KG Hauptstraße 7 D-75040 Ulmberg Tel. +49(0)71412044-100		64.4016VL313	
					MNR: 116571		IDENT: D-EWS-042197 - Blatt - page 1 (1)	