

Schwenkbereich $\pm 105^\circ$
Swivel area $\pm 105^\circ$

Spannzange / collet ER25 DIN6499
Spannbereich / clamping range: 1,0 - 16,0

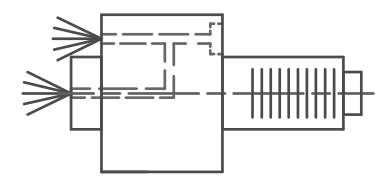

Innen- und Aussenkuehlung / Inside and outside coolant supply
Kein Trockenlauf / No dry run
Kuehlmittelfiltrierung 50μ / coolant filtration 50μ

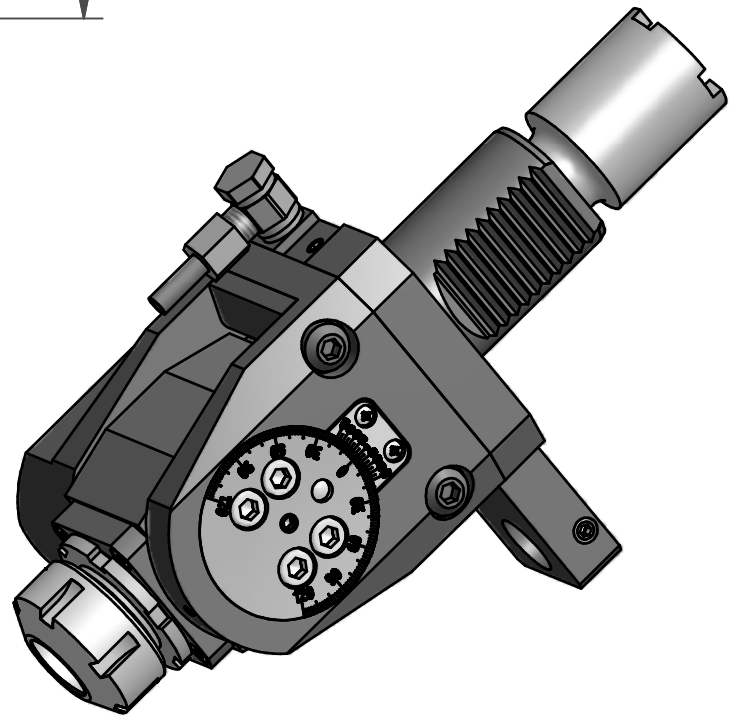

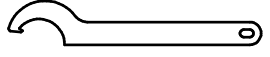
Hakenschlüssel
mit Nase
Hook wrench with
nose end
DIN1810 A 45x50

Spannzangenschlüssel
Clamping wrench
225

Copyright **EWS Tool Technologies**
Weitergabe und Vervielfaeltigung dieser Unterlage,
Verwertung und Mitteilung ihres Inhalts nicht
gestattet, soweit nicht ausdruercklich zugestanden.
Zuwiderhandlungen verpflichten zu Schadenersatz.

<p>Bemerkung - Note Nicht ohne Kuehlmittel betreiben! Not for use without coolant-fluid!</p>	<p>Technische Daten - technical data M1 / M2 = 20 / 20 Nm n1 / n2 = 6000 / 6000 1/min i (N1:N2) = 1:1 pmax = 70 bar</p>	<p>Benennung - Title Schwenkkopf Swivel head</p>	<table border="1"> <tr> <th>name</th> <th>date</th> </tr> <tr> <td>Theiss</td> <td>10.09.2014</td> </tr> </table> <p>EWS Weigele GmbH & Co. KG Maybachstr. 1 D-73066 Uhingen Tel. +49(0)7161/93040-10</p>	name	date	Theiss	10.09.2014	<p>Technische Aenderungen vorbehalten! Subject to technical modifications!</p> <p>Nr. 63.4025LB25IK</p> <p>File: D-EWS-162840-.idw</p>	<p>DIN A3 Blatt - page 1 (1)</p>
name	date								
Theiss	10.09.2014								