

12 11 10 9 8 7 6 5 4 3 2 1

H G F E D C B A

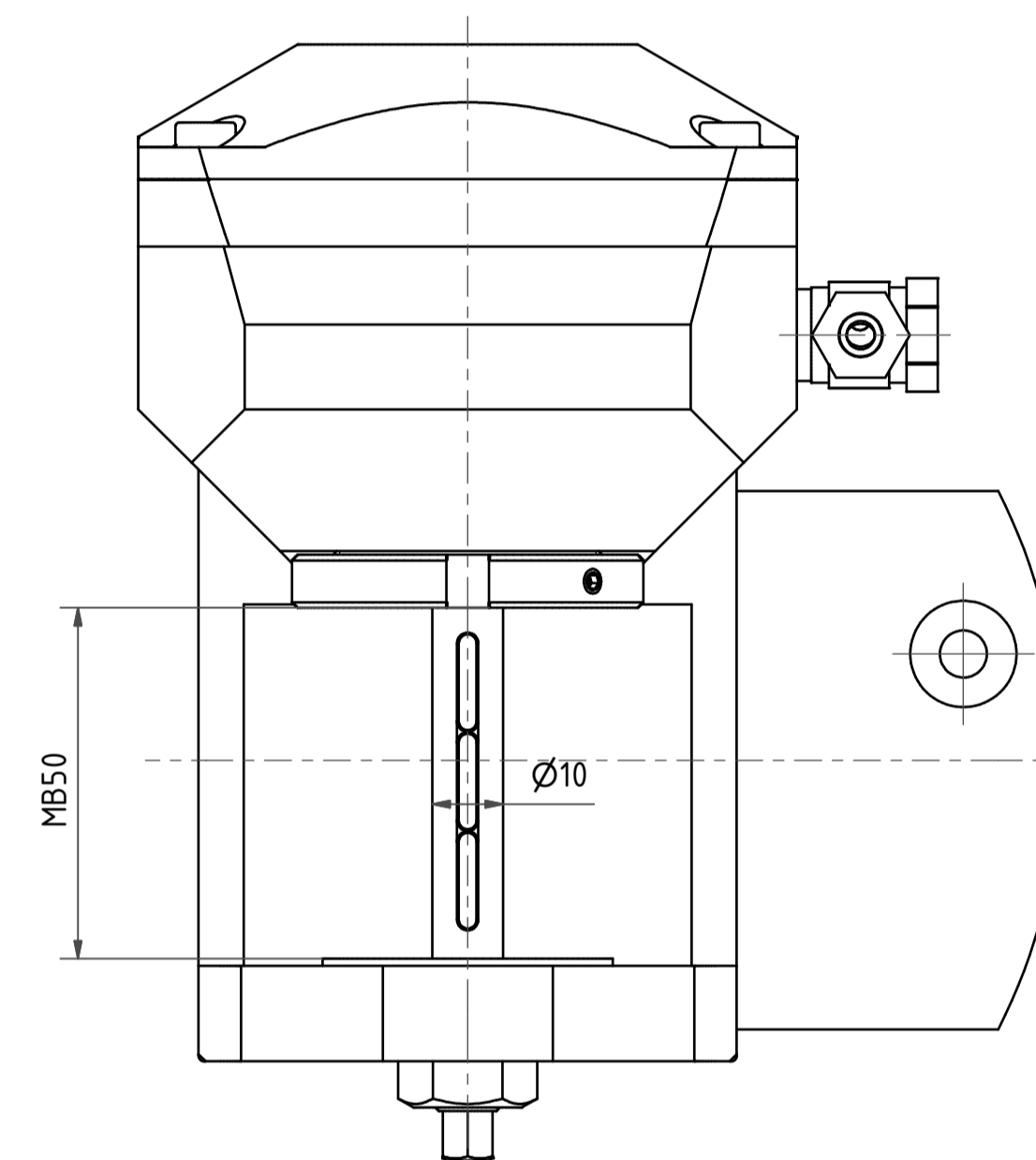

Fraeserwelle austauschbar  
spindle removable

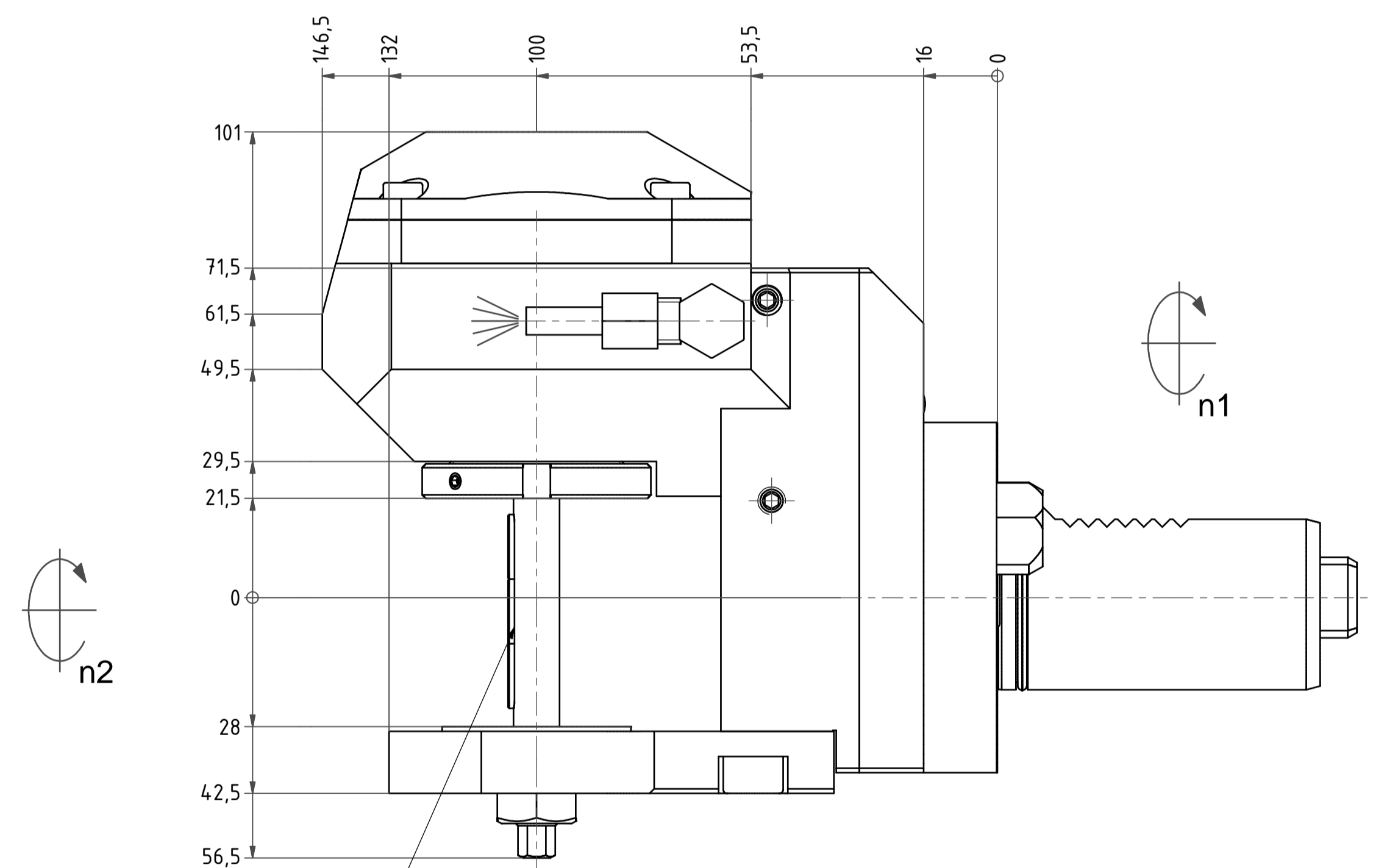
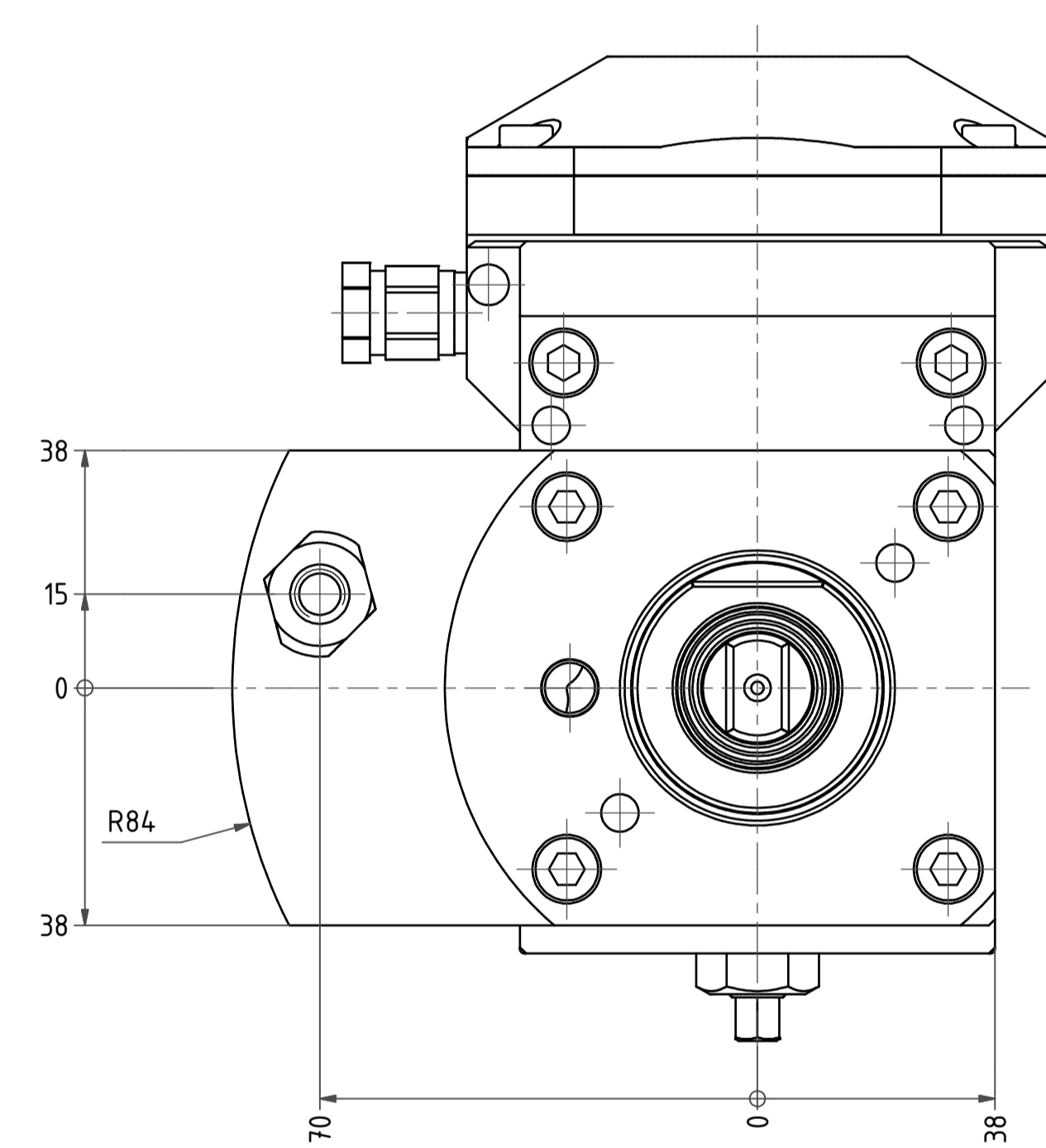
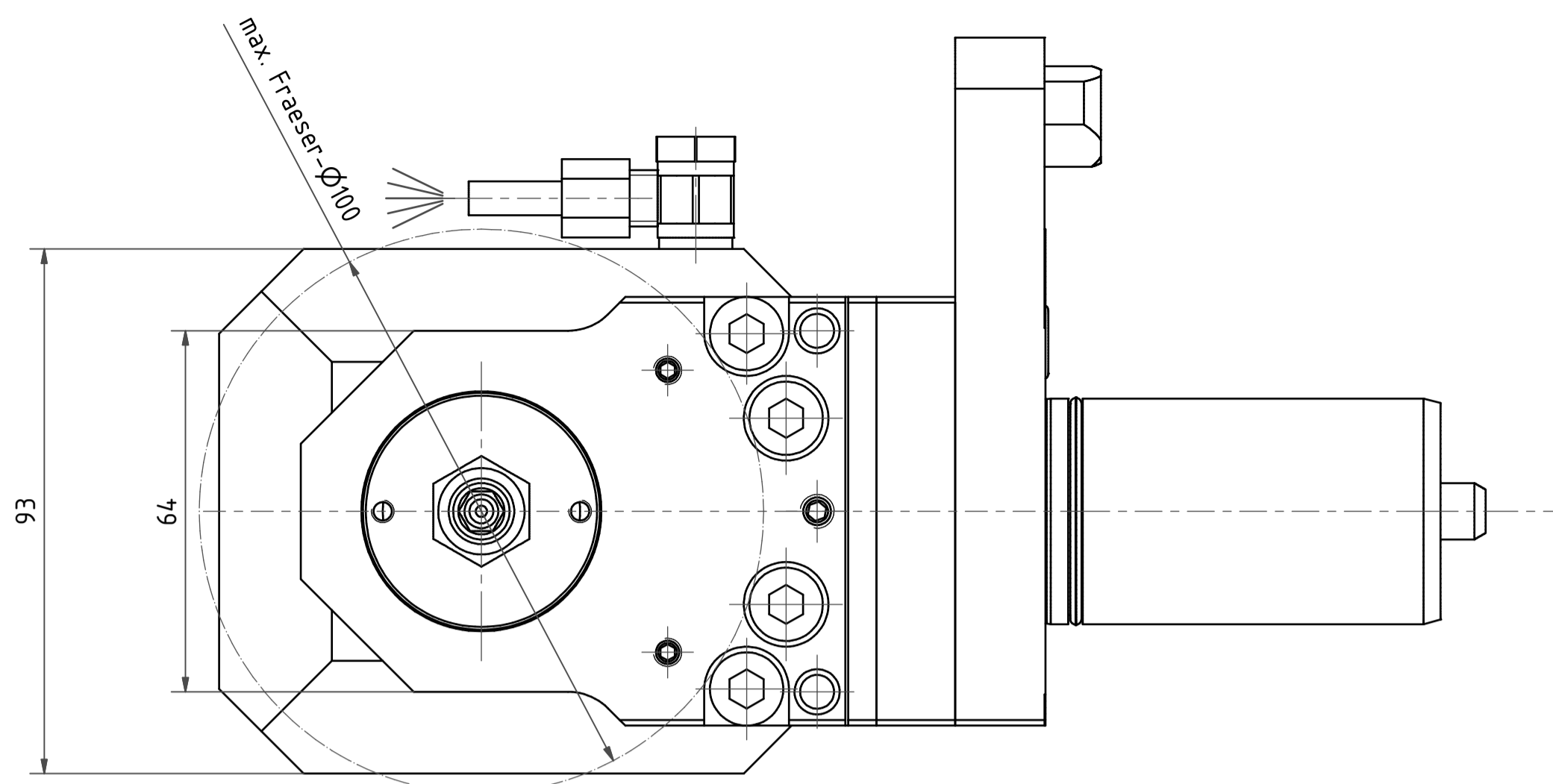
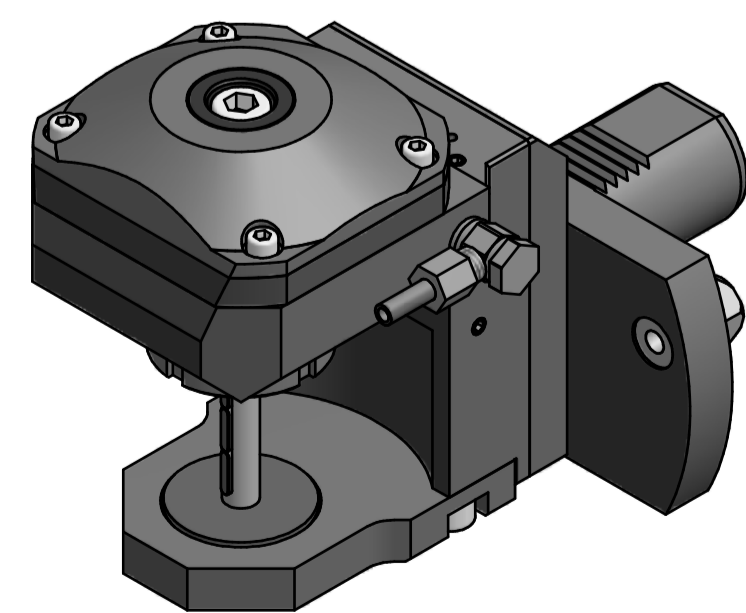
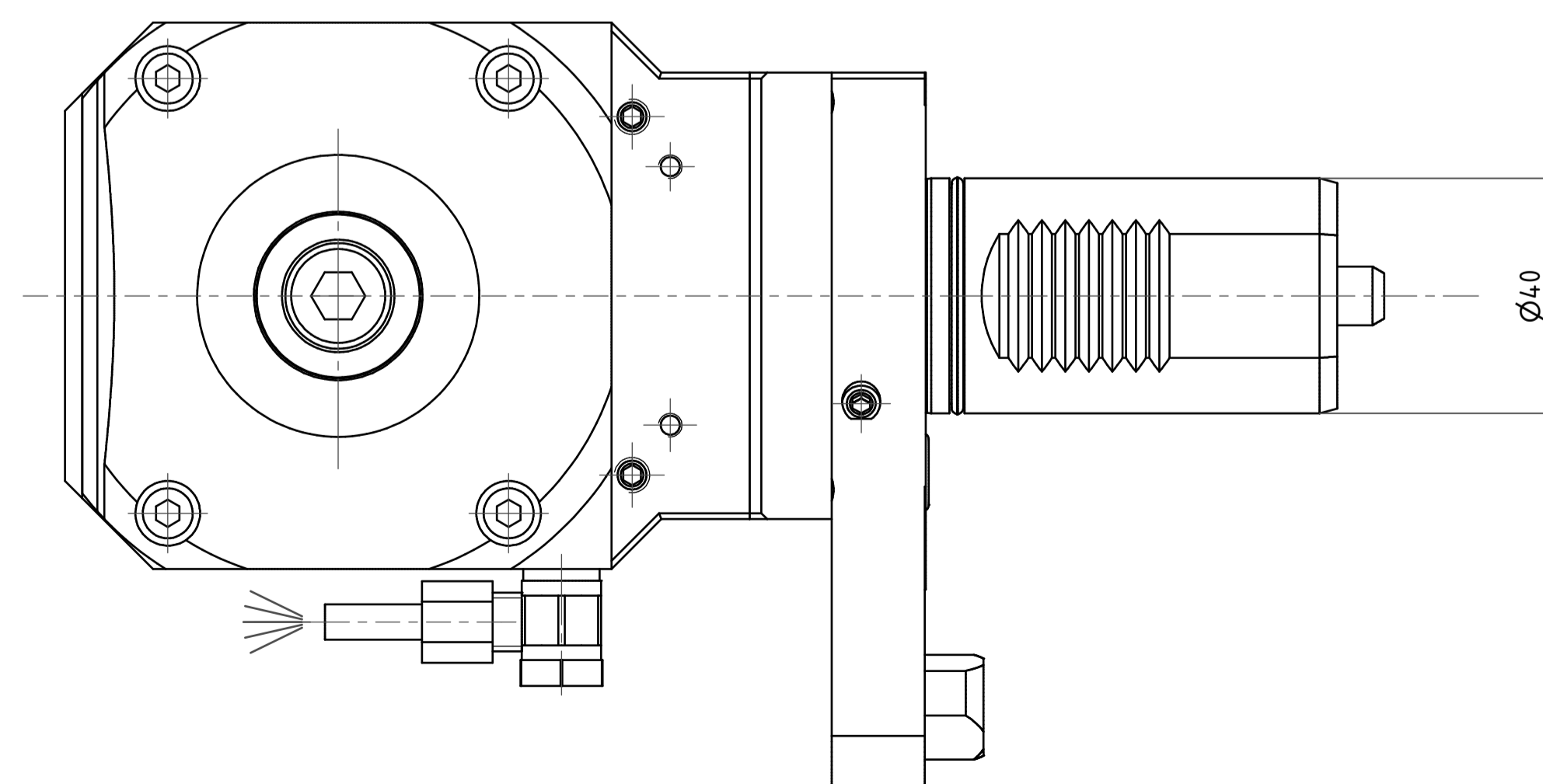

Copyright **EWS Tool Technologies**  
Weitergabe und Vervielfältigung dieser Unterlage  
Verwertung und Mitteilung ihres Inhalts nicht  
gestattet, soweit nicht ausdrücklich zugestanden.  
Zuwerhandlungen verpflichten zu Schadenersatz.

Bemerkung - Note

Technische Daten - Technical data  
M1 / M2 = 50 / 150 Nm  
n1 / n2 = 6000 / 2000 1/min  
i (N1:N2) = 3:1

Bemerkung - Note  
**Scheibenfräserkopf**  
**Radial saw milling head**

name	date	Technische Änderungen vorbehalten!
Thiess	15.09.2014	Subject to technical modifications!
<b>64.4010MP62013</b>		DIN A1
MNR: 115121	IDENT: D-EWS-163082	Blatt - page 1 (1)

12 11 10 9 8 7 6 5 4 3 2 1

H G F E D C B A