

min. 62  
max. 65,5

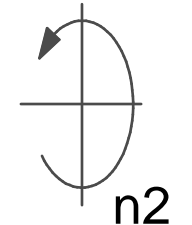

SW30  
Ø34

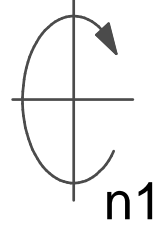

30  
30  
Ø25

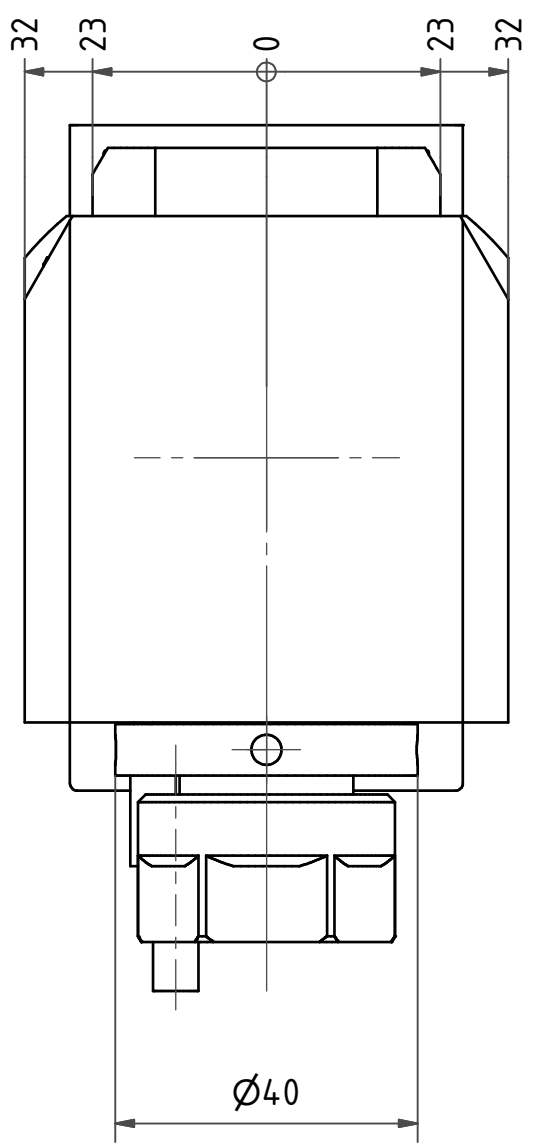

Spannzange / collet ER20 DIN6499  
Spannbereich / clamping range: 1,0 - 13,0

Gewindebohrzange / tapping collet  
ET-1-20 M2-M6

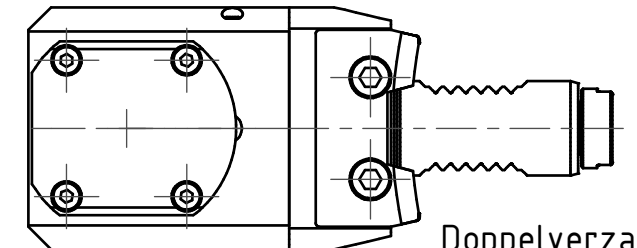

Doppelverzahnung Lizenz Traub  
double tooth system licence Traub

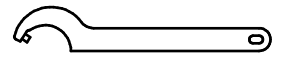
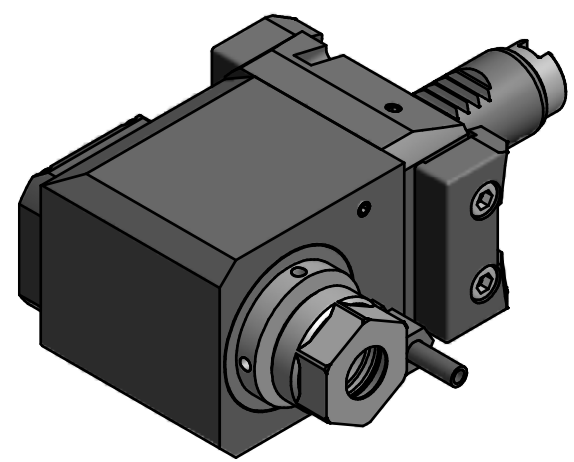

Hakenschlüssel  
mit Zapfen  
Hook wrench  
with fixed pin  
DIN1810 B 40x42

Copyright **EWS Tool Technologies**  
Weitergabe und Vervielfaeltigung dieser Unterlage,  
Verwertung und Mitteilung ihres Inhalts nicht  
gestattet, soweit nicht ausdrecklich zugestanden.  
Zuwiderhandlungen verpflichten zu Schadenersatz.

Bemerkung - Note	Technische Daten - technical data M1 / M2 = 20 / 40 Nm n1 / n2 = 6000 / 3000 1/min i (N1:N2) = 2:1	Benennung - Title <b>Radial Bohr und Fräskopf</b> <i>Radial drilling and milling head</i>	name	date	Technische Aenderungen vorbehalten! Subject to technical modifications!	
			drawing	M. Simoniello		
			EWS Weigete GmbH & Co. KG Maybachstr. 1 D-73066 UHINGEN Tel. +49(0)7161/93040-100		Nr. <b>60.2520G200RLI2</b>	DIN A3
			MNR: 109164		IDENT: D-EWS-186518 -	Blatt - page 1 (1)