

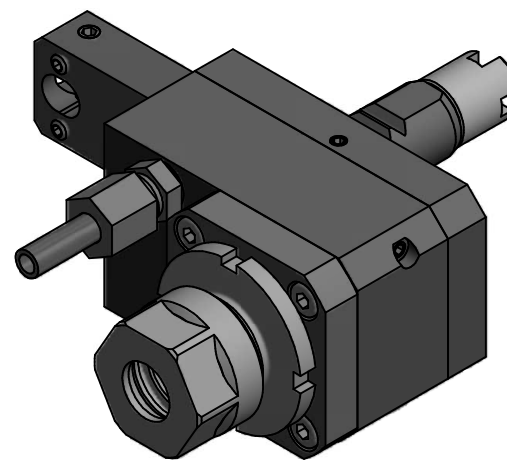

Spannzange / Collet ER16 DIN6499
 Spannbereich / Clamping range: 1,0 - 10,0

Gewindebohrzange / Tapping Collet
 ET-1-16 M1-M6



Hakenschlüssel
 mit Nase
 Hook wrench with
 nose end
 DIN1810 A 36x38

Copyright **EWS Tool Technologies**
 Weitergabe und Vervielfältigung dieser Unterlage,
 Verwertung und Mitteilung ihres Inhalts nicht
 gestattet, soweit nicht ausdrücklich zugestanden.
 Zuwiderhandlungen verpflichten zu Schadenersatz.

Bemerkung - Note	Technische Daten - technical data Weight = 1.016 [kg] Torque max. (M1/M2) = 6,3 / 3 [Nm] Speed max. (n1/n2) = 8000 / 16000 [1/min] Gear ratio (i)=n1:n2 = 1:2	Benennung - Title Axial Bohr u. Fräskopf achsversetzt <i>Ax. drill. and mill. head offset</i>	 EWS Weigelt GmbH & Co. KG Maybachstr. 1 D-73066 Uhingen www.ews-tools.de Nr. - No. 50.1616TOEMRI1	Technische Änderungen vorbehalten! Subject to technical modifications! IDENT: DEWS021698 REV: -/B MNR. 149541	
------------------	---	--	---	---	---