

Spannzange / collet ER25 DIN6499
Spannbereich / clamping range: 1,0 - 16,0

Gewindebohrzange / tapping collet
ET-1-25 M3-M10

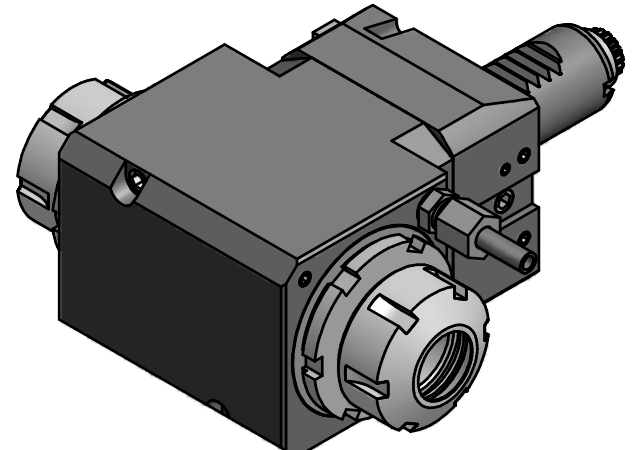
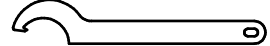

Hakenschlüssel
mit Nase
Hook wrench with
nose end
DIN1810 A 52x55

Spannzangenschlüssel
Clamping wrench
225

Copyright **EWS Tool Technologies**
Weitergabe und Vervielfältigung dieser Unterlage,
Verwertung und Mitteilung ihres Inhalts nicht
gestattet, soweit nicht ausdrücklich zugestanden.
Zuwendungen verpflichten zu Schadenersatz.

Bemerkung - Note

Technische Daten - technical data

Weight	= 3.932 [kg]
Torque max. (M1/M2)	= 25 / 25 each Sp. [Nm]
Speed max. (n1/n2)	= 8000 / 8000 [1/min]
Gear ratio (i)=n1:n2	= 1:1

Benennung - Title

Radial Bohr und Fräskopf
Radial drilling and milling head

EWS
Tool Technologies

EWS Weigele GmbH & Co. KG
Maybachstr. 1
D-73066 Uhingen
www.ews-tools.de

Nr. - No.
60.2525LD5480FE

Technische Änderungen vorbehalten!
Subject to technical modifications!

IDENT: D-EWS-053154

REV: B/-

MNR.
133812

