

Spannzange / *collet* ER25 DIN6499  
 Spannbereich / *clamping range*: 1,0 - 16,0

Gewindebohrzange / *tapping collet*  
 ET-1-25 M3-M10

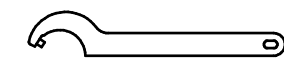

Hakenschlüssel  
 mit Zapfen  
*Hook wrench  
 with fixed pin*  
 DIN1810 B 40x42

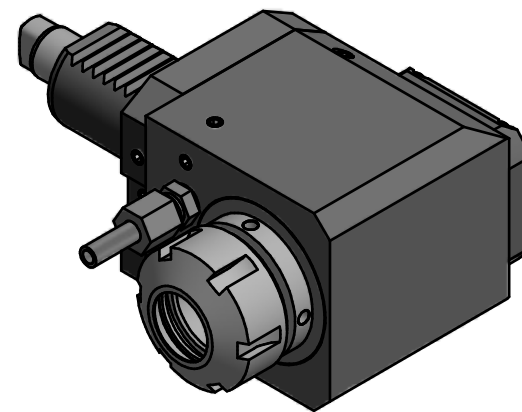
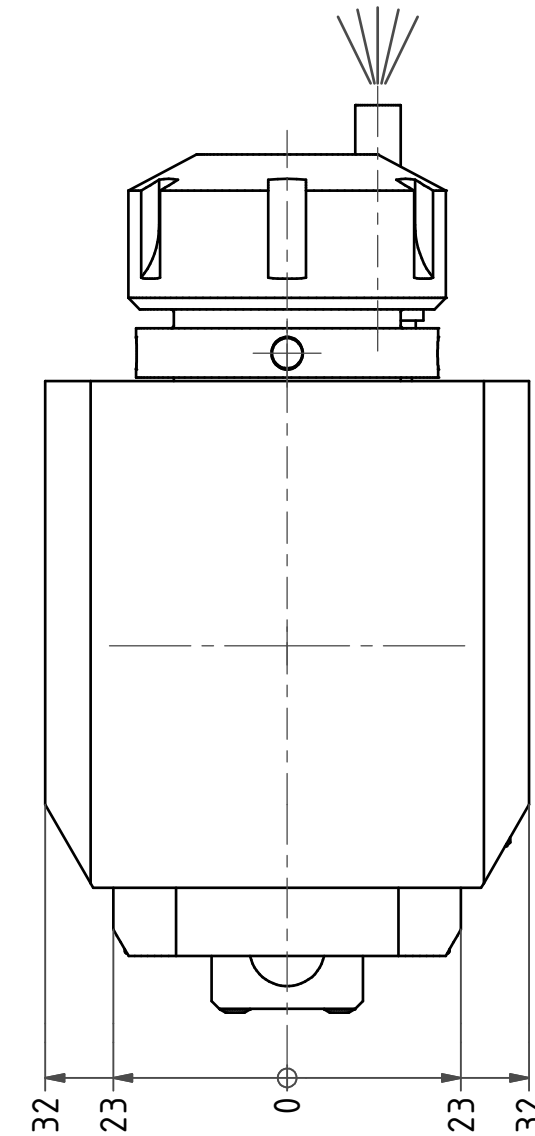
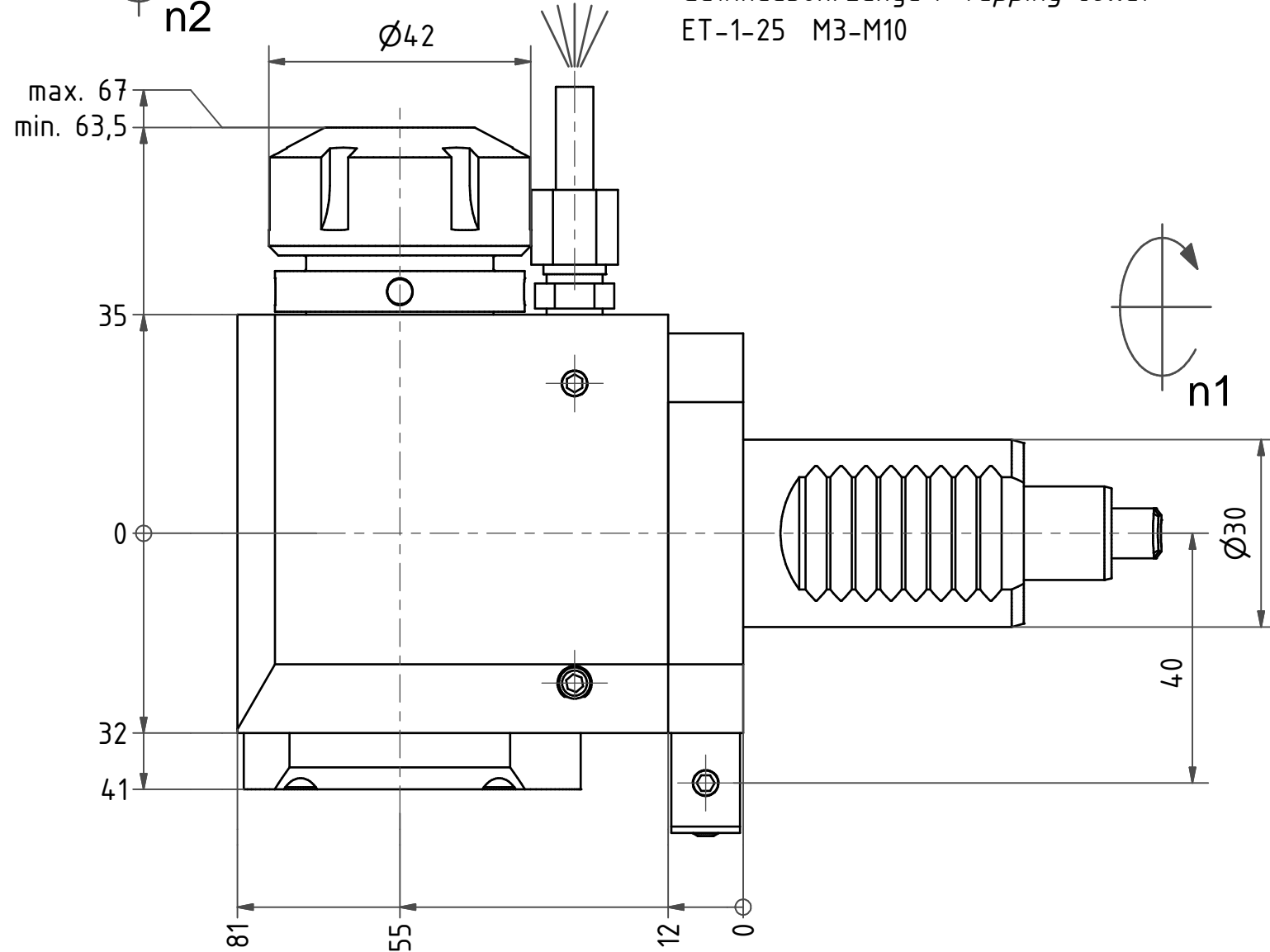
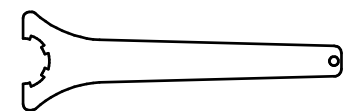

Spannzangenschlüssel  
*Clamping wrench*  
 225

Copyright **EWS Tool Technologies**  
 Weitergabe und Vervielfältigung dieser Unterlage,  
 Verwertung und Mitteilung ihres Inhalts nicht  
 gestattet, soweit nicht ausdrücklich zugestanden.  
 Zuwiderhandlungen verpflichten zu Schadenersatz.

Bemerkung - *Note*

Technische Daten - *technical data*

*Weight* = 2.776 [kg]  
*Torque max.* (M1/M2) = 25 / 25 [Nm]  
*Speed max.* (n1/n2) = 8000 / 8000 [1/min]  
*Gear ratio* (i)=n1:n2 = 1:1

Benennung - *Title*

Radial Bohr und Fräskopf  
*Radial drilling and milling head*



Nr. - *No.*  
 60.3025HD1809L

Technische Änderungen vorbehalten!  
*Subject to technical modifications!*

IDENT: D-EWS-138564



REV: A/-

MNR.

157442

