

Spannzange / collet ER20 DIN6499
 Spannungsbereich / clamping range: 1,0 - 13,0

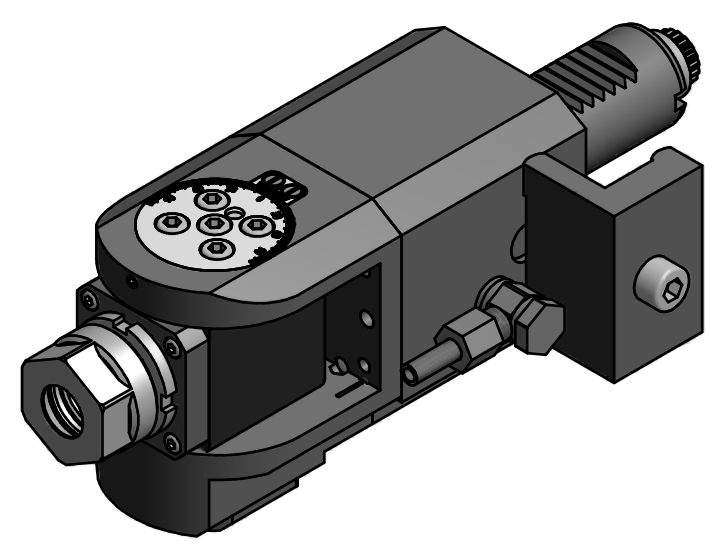

Gewindebohrzange / tapping collet
 ET-1-20 M2-M6

Schwenkbereich ±105°
 swivel area ±105°

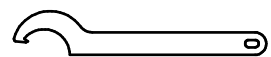

 Hakenschlüssel
 mit Nase
 Hook wrench with
 nose end
 DIN1810 A 34x36

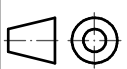
Copyright **EWS Tool Technologies**
 Weitergabe und Vervielfältigung dieser Unterlage,
 Verwertung und Mitteilung ihres Inhalts nicht
 gestattet, soweit nicht ausdrücklich zugestanden.
 Zuwiderhandlungen verpflichten zu Schadenersatz.

| | | | | | | |
|------------------|---|---|---|--------|--|---|
| Bemerkung - Note | Technische Daten - technical data M1 / M2 = 16 / 16 Nm n1 / n2 = 8000 / 8000 1/min i (N1:N2) = 1:1 | Benennung - Title Schwenkkopf <i>Swivel head</i> | name | date | Technische Änderungen vorbehalten! <i>Subject to technical modifications!</i> |  DIN A3 |
| | | | drawing | Theiss | | |
| | | |  EWS Weigete GmbH & Co. KG Maybachstr. 1 D-73066 Uhingen Tel. +49(0)7161/93040-100 | | Nr. 63.3020LCTXOT08 | |
| | | | MNR: 133873 | | IDENT: D-EWS-162682 A | |
| | | | Blatt - page | | 1 (1) | |