

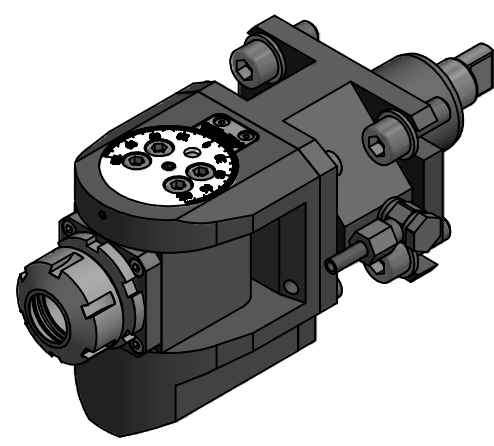

Spannzange / collet ER25 DIN6499
Spannbereich / clamping range: 1,0 - 16,0

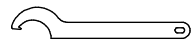

Gewindebohrzange / tapping collet
ET-1-25 M3-M10



 Hakenschlüssel
mit Nase
Hook wrench with
nose end
DIN1810 A 45x50

 Spannzangenschlüssel
Clamping wrench
225

Copyright **EWS Tool Technologies**
Weitergabe und Vervielfältigung dieser Unterlage,
Verwertung und Mitteilung ihres Inhalts nicht
gestattet, soweit nicht ausdrücklich zugestanden.
Zuwerhandlungen verpflichtet zu Schadenersatz.

Bemerkung - Note	Technische Daten - technical data Weight = 5.500 [kg] Torque max. (M1/M2) = 25 / 25 [Nm] Speed max. (n1/n2) = 6000 / 6000 [1/min] Gear ratio (i)=n1:n2 = 1:1	Benennung - Title Schwenkopf Swivel head	 EWS Weigelt GmbH & Co. KG Maybachstr. 1 D-73066 Uhingen www.ews-tools.de	Technische Änderungen vorbehalten! Subject to technical modifications! IDENT: D-EWS-012696	 REV: -/A MNR. 122295	
			Nr. - No. 63.4025MT12			