

Doppelverzahnung Lizenz Traub
double tooth system licence Traub

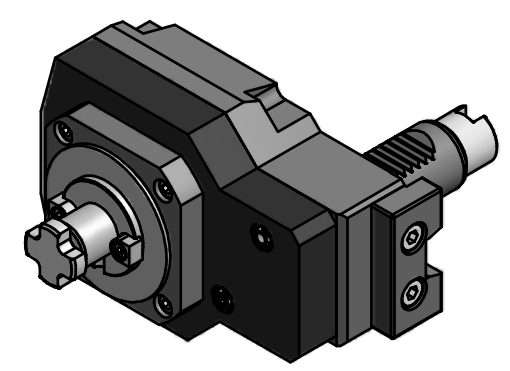

Copyright **EWS Tool Technologies**
 Weitergabe und Vervielfaeltigung dieser Unterlage,
 Verwertung und Mitteilung ihres Inhalts nicht
 gestattet, soweit nicht ausdrecklich zugestanden.
 Zuwiderhandlungen verpflichten zu Schadenersatz.

Bemerkung - Note mit Kegelrollenlagern <i>with taper roller bearings</i>	Technische Daten - technical data M1 / M2= 20 /60 Nm n1 / n2 = 6000 /2000 1/min i (N1:N2) = 3:1	Benennung - Title Axial Fräskopf , achsversetzt <i>Axial milling head offset</i>	name	date	Technische Aenderungen vorbehalten! <i>Subject to technical modifications!</i>	
			drawing	F.Miltschuh		
					Nr. 52.3022KRG300RLI3V	DIN A3
			<small>EWS Weigete GmbH & Co. KG Maybachstr. 1 D-73066 Uhingen Tel. +49(0)7161/93040-100</small>			
			MNR: 157371		IDENT: D-EWS-162098 -	Blatt - page 1 (1)