

Spannzange / collet ER20 DIN6499  
 Spannbereich / clamping range: 1,0 - 13,0

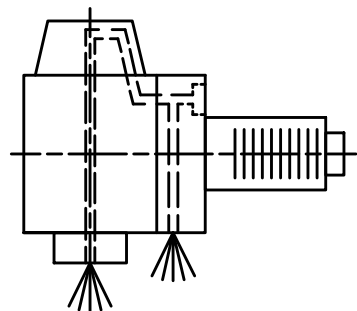

Innen- und Aussenkuehlung / Inside and outside coolant supply  
 Kein Trockenlauf / No dry run  
 Kuehlmittelfiltrierung <math>50\mu</math> / coolant filtration <math>50\mu</math>

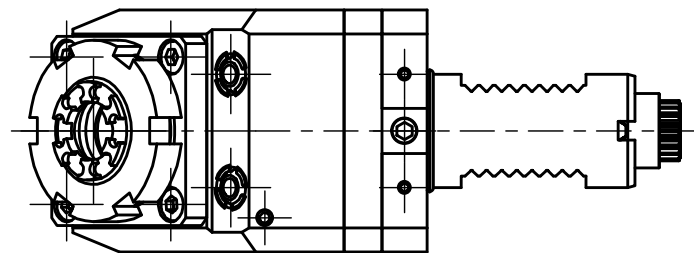

Doppelverzahnung Lizenz Traub  
 double tooth system licence Traub

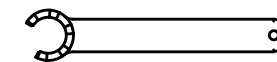
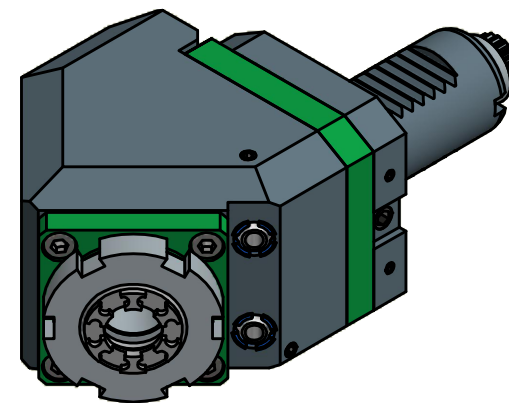

Spannzangenschlüssel für  
 innenliegende Mutter  
 Clamping wrench for  
 internal collet  
 220AX

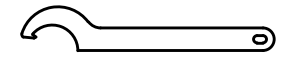

Hakenschlüssel  
 mit Nase  
 Hook wrench with  
 nose end  
 DIN1810 A 45x50

Copyright **EWS Tool Technologies**  
 Weitergabe und Vervielfaeltigung dieser Unterlage,  
 Verwertung und Mitteilung ihres Inhalts nicht  
 gestattet, soweit nicht ausdrecklich zugestanden.  
 Zuwiderhandlungen verpflichten zu Schadenersatz.

Bemerkung - Note  
 Nicht ohne Kuehlmittel betreiben!  
 Not for use without coolant-fluid!

Technische Daten - technical data  
 Weight = 2.932 [kg]  
 Torque max. (M1/M2) = 24 / 12 [Nm]  
 Speed max. (n1/n2) = 6000 / 12000 [1/min]  
 Gear ratio (i)=n1:n2 = 1:2  
 Pressure (pmax) = 70 [bar]

Benennung - Title  
**Radial Bohr und Fräskopf**  
**Radial drilling and milling head**

**EWS** Tool Technologies  
 EWS Weigle GmbH & Co. KG  
 Maybachstr. 1  
 D-73066 UHINGEN  
 www.ews-tools.de

Technische Aenderungen vorbehalten!  
 Subject to technical modifications!  
 IDENT: D-EWS-003751

REV: -/-

Nr. - No.  
**60.3020CTXRLIKI1TKW45IM**

MNR.  
**128722**

