

Spannzange / collet ER25 DIN6499
Spannbereich / clamping range: 1,0 - 16,0

Gewindebohrzange / tapping collet
ET-1-25 M3-M10

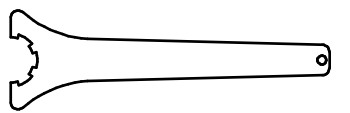

Spannzangenschlüssel
Clamping wrench
225

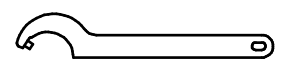

Hakenschlüssel
mit Zapfen
Hook wrench
with fixed pin
DIN1810 B 45x50

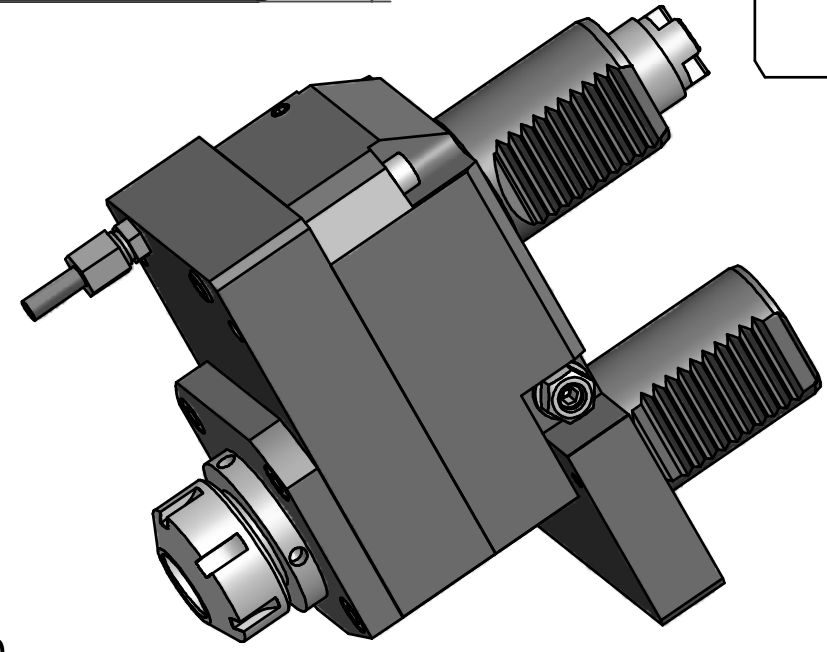

Copyright **EWS Tool Technologies**
Weitergabe und Vervielfaeltigung dieser Unterlage,
Verwertung und Mitteilung ihres Inhalts nicht
gestattet, soweit nicht ausdruuecklich zugestanden.
Zuwiderhandlungen verpflichten zu Schadenersatz.

Bemerkung - Note 	Technische Daten - technical data M1 / M2 = 50 / 25 Nm n1 / n2 = 6000 / 12000 1/min i (N1:N2) = 1:2	Benennung - Title Axial Bohr u. Fräskopf achsversetzt Ax. drill. and mill. head offset	<table border="1"> <tr> <th>name</th> <th>date</th> </tr> <tr> <td>drawing R.Kondratschin</td> <td>10.02.2010</td> </tr> </table> <p>EWS EWS Weigele GmbH & Co. KG Maybachstr. 1 D-73066 Uhlingen Tel. +49(0)7161/83040-100</p>	name	date	drawing R.Kondratschin	10.02.2010	Technische Aenderungen vorbehalten! Subject to technical modifications! Nr. 50.4025GU800R11 MNR: 148743 IDENT: D-EWS-084554 - Blatt - page 1 (1)
name	date							
drawing R.Kondratschin	10.02.2010							