

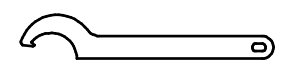

Spannzange / collet ER40 DIN6499
 Spannbereich / clamping range: 3,0 - 26,0

Gewindebohrzange / tapping collet
 ET-1-40 M6-M16

 Hakenschlüssel
 mit Nase
 Hook wrench with
 nose end
 DIN1810 A 58x62

 Spannzangenschlüssel
 Clamping wrench
 240

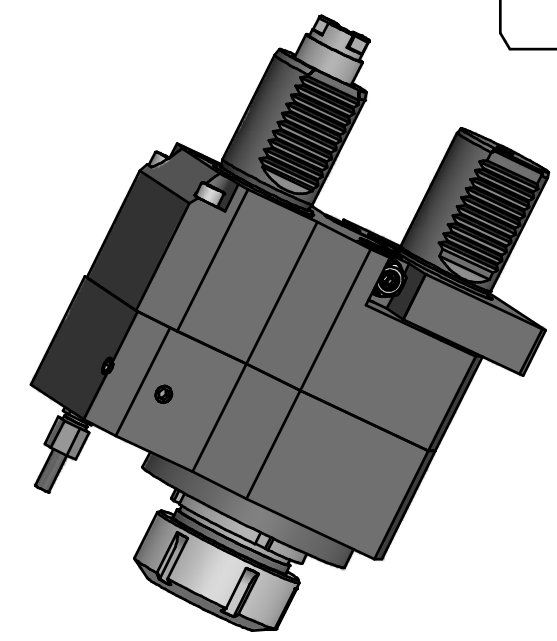

Copyright **EWS Tool Technologies**
 Weitergabe und Vervielfaeltigung dieser Unterlage,
 Verwertung und Mitteilung ihres Inhalts nicht
 gestattet, soweit nicht ausdrecklich zugestanden.
 Zuwiderhandlungen verpflichten zu Schadenersatz.

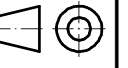
Bemerkung - Note 	Technische Daten - technical data M1 / M2 = 40 / 120 Nm n1 / n2 = 6000 / 2000 1/min i (N1:N2) = 2,895:1	Benennung - Title Axial Bohr u. Fräskopf achsversetzt Ax. drill. and mill. head offset	<table border="1"> <tr> <td>name</td> <td>date</td> </tr> <tr> <td>Seeh</td> <td>12.01.2010</td> </tr> </table>  EWS Weigete GmbH & Co. KG Maybachstr. 1 D-73066 Uhlingen Tel. +49(0)7161/93040-100	name	date	Seeh	12.01.2010	Technische Aenderungen vorbehalten! Subject to technical modifications! Nr. 50.4040GU800R13 MNR: 115251 IDENT: D-EWS-083384 - Blatt - page 1 (1)	 DIN A3
name	date								
Seeh	12.01.2010								