

Kopf kann um 90° gedreht werden.
head can be rotated 90 °

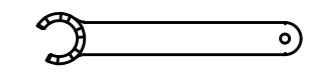

Spannzangenschlüssel für
innenliegende Mutter
Clamping wrench for
internal collet
225AX

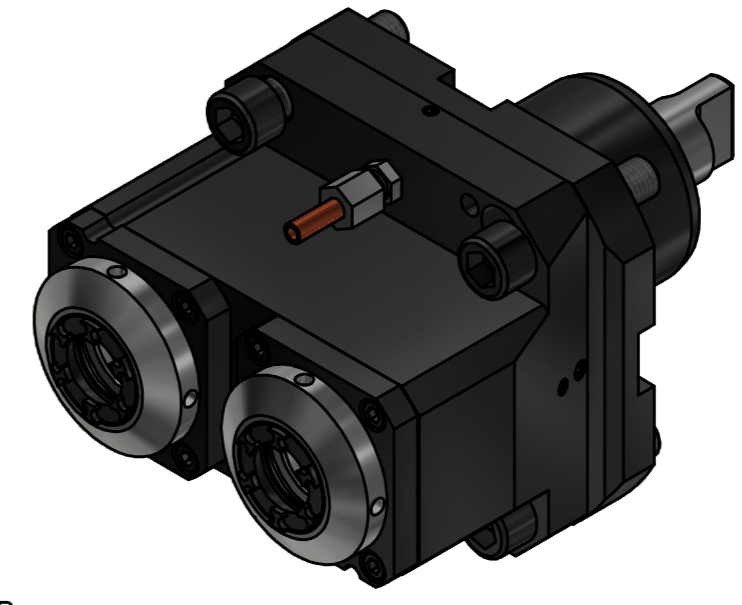
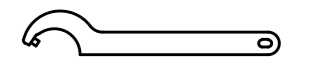

Hakenschlüssel
mit Zapfen
Hook wrench
with fixed pin
DIN1810 B 52x55

Copyright EWS Tool Technologies
Weitergabe und Vervielfältigung dieser Unterlage,
Verwertung und Mitteilung ihres Inhalts nicht
gestattet, soweit nicht ausdrücklich zugestanden.
Zuwerhandlungen verpflichten zu Schadenersatz.

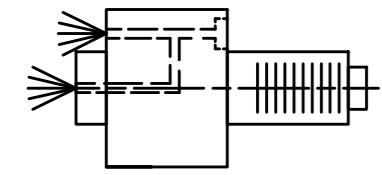

Innen- und Aussenkuehlung / Inside and outside coolant supply
Kein Trockenlauf / No dry run
Kuehlmittelfiltrierung+50µ / coolant filtration+50µ

Bemerkung - Note
Nicht ohne Kuehlmittel betreiben!
Not for use without coolant-fluid!

Technische Daten - technical data
Weight = 8,022 [kg]
Torque max. (M1/M2) = 30 / 30 | 30 [Nm]
Speed max. (n1/n2) = 6000 / 6000 | 6000 [1/min]
Gear ratio (i)=n1:n2 = 1:1 | 1:1
Pressure (pmax) = 70 [bar]

Benennung - Title
Axial Bohr und Fräskopf
Axial drilling and milling head

EWS Tool Technologies
EWS Weigle GmbH & Co. KG
Maybachstr. 1
D-73066 Uhlingen
www.ews-tools.de

Technische Aenderungen vorbehalten!
Subject to technical modifications!
IDENT: DEWS119317
REV: -/D
MNR.
148585

