

Spannzange / collet ER20 DIN64.99  
 Spannbereich / clamping range: 1,0 - 13,0

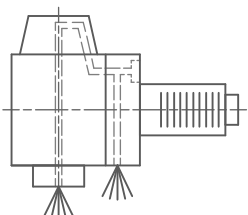

Innen- und Aussenkuehlung / Inside and outside coolant supply  
 Kein Trockenlauf / No dry run  
 Kuehlmittelfiltrierung <math>< 50\mu</math> / coolant filtration <math>< 50\mu</math>

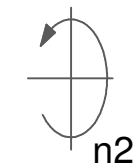
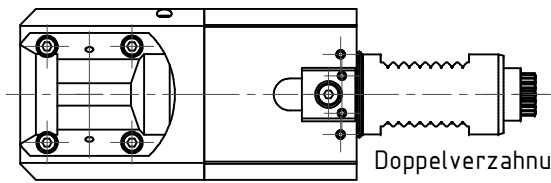

Doppelverzahnung Lizenz Traub  
 double tooth system licence Traub

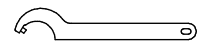
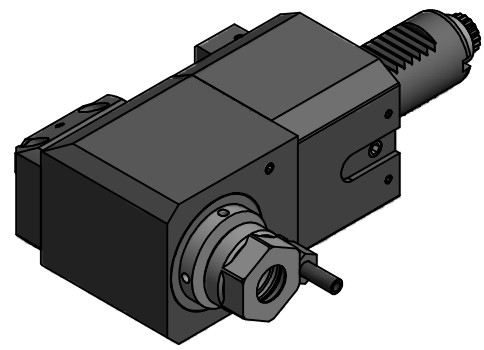
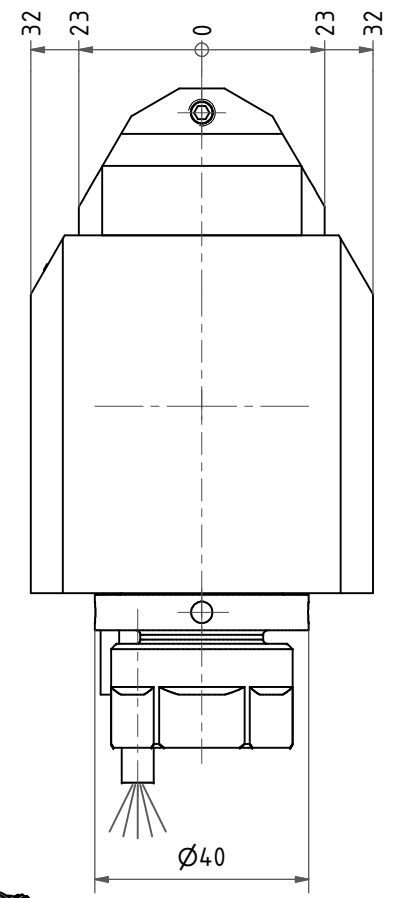

Hakenschlüssel  
 mit Zapfen  
 Hook wrench  
 with fixed pin  
 DIN1810 B 40x42

Copyright **EWS Tool Technologies**  
 Weitergabe und Vervielfaeltigung dieser Unterlage,  
 Verwertung und Mitteilung ihres Inhalts nicht  
 gestattet, soweit nicht ausdruercklich zugestanden.  
 Zuwaiderhandlungen verpflichten zu Schadenersatz.

Bemerkung - Note  
 Nicht ohne Kuehlmittel betreiben!  
 Not for use without coolant-fluid!

Technische Daten - technical data	
Weight	= 4.176 [kg]
Torque max. (M1/M2)	= 25 / 25 [Nm]
Speed max. (n1/n2)	= 8000 / 8000 [1/min]
Gear ratio (i)=n1:n2	= 1:1
Pressure (pmax)	= 70 [bar]

Benennung - Title  
**Radial Bohr und Fräskopf**  
**Radial drilling and milling head**

**EWS**  
 Tool Technologies  
EWS Weigl GmbH & Co. KG  
 Maybachstr. 1  
 D-73066 Uhlingen  
 www.ews-tools.de

Nr. - No.  
**60.3020LCTXRLIK**

Technische Aenderungen vorbehalten! Subject to technical modifications!	 REV: -/A MNR. <b>142692</b>
IDENT: DEWS008714	

