

Spannzange / collet ER20 DIN6499  
 Spannungsbereich / clamping range: 1,0 - 13,0  
 Gewindebohrzange / tapping collet  
 ET-1-20 M2-M6

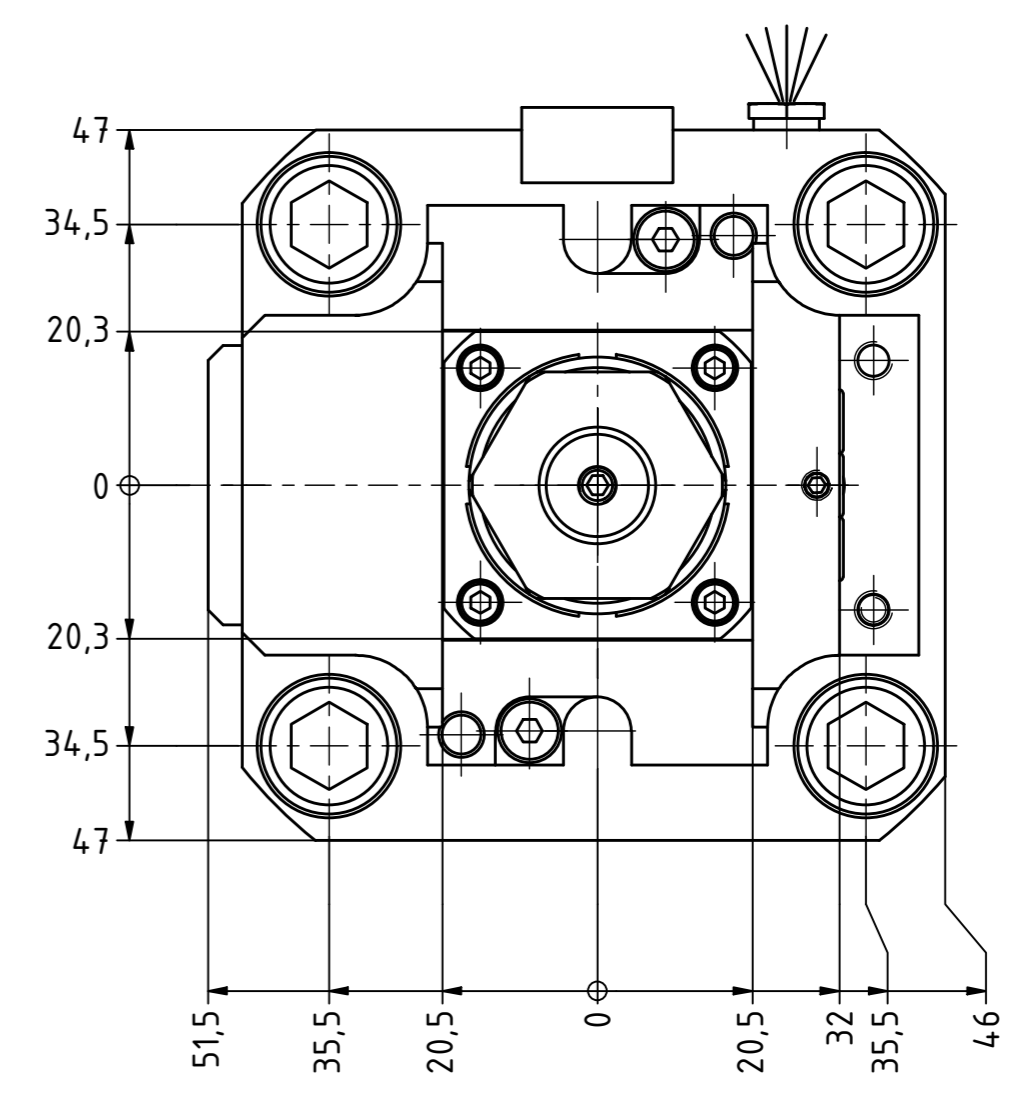

### Platzverhältnisse / *space conditions* **Nakamura TW20**

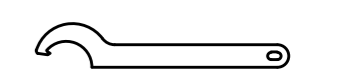
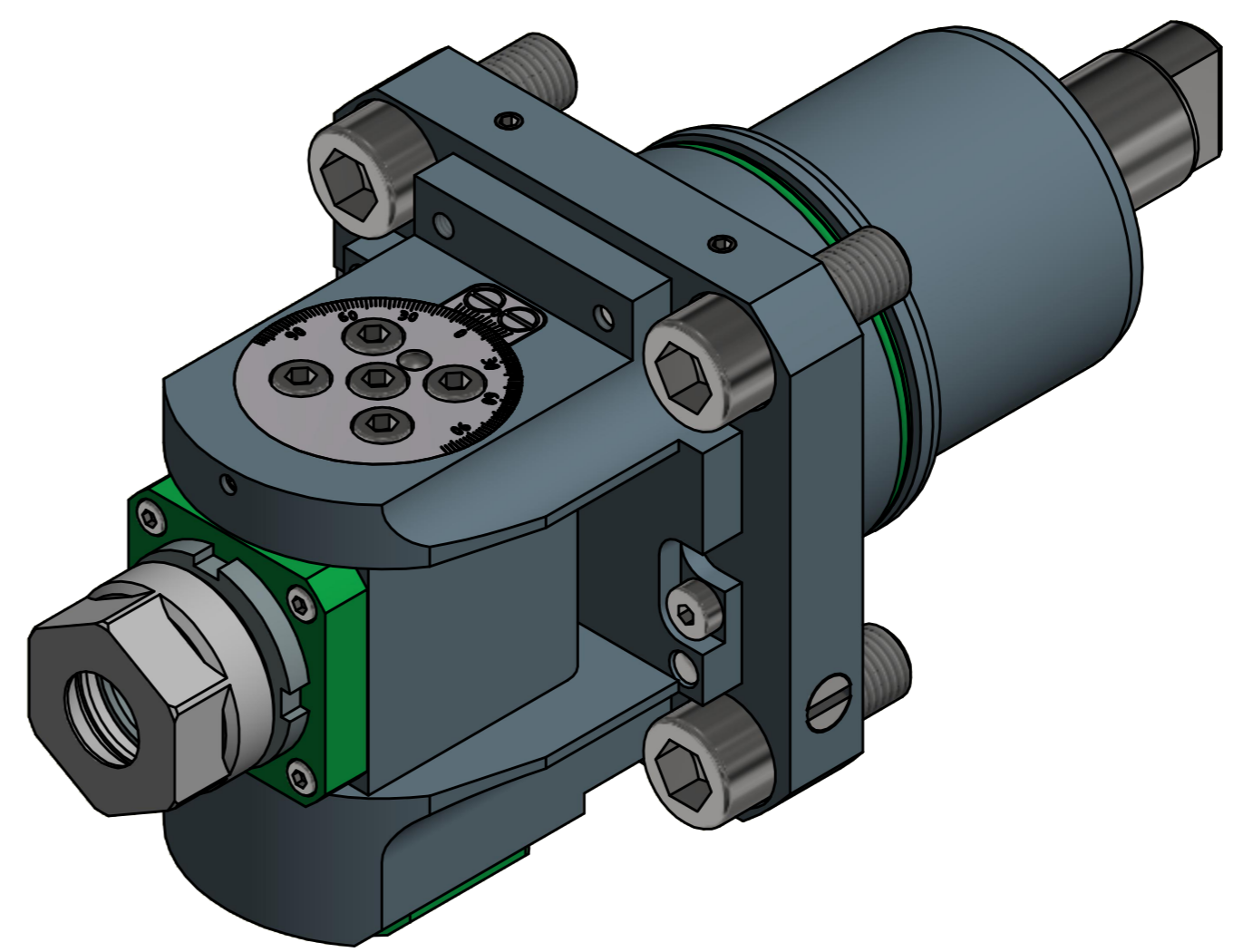
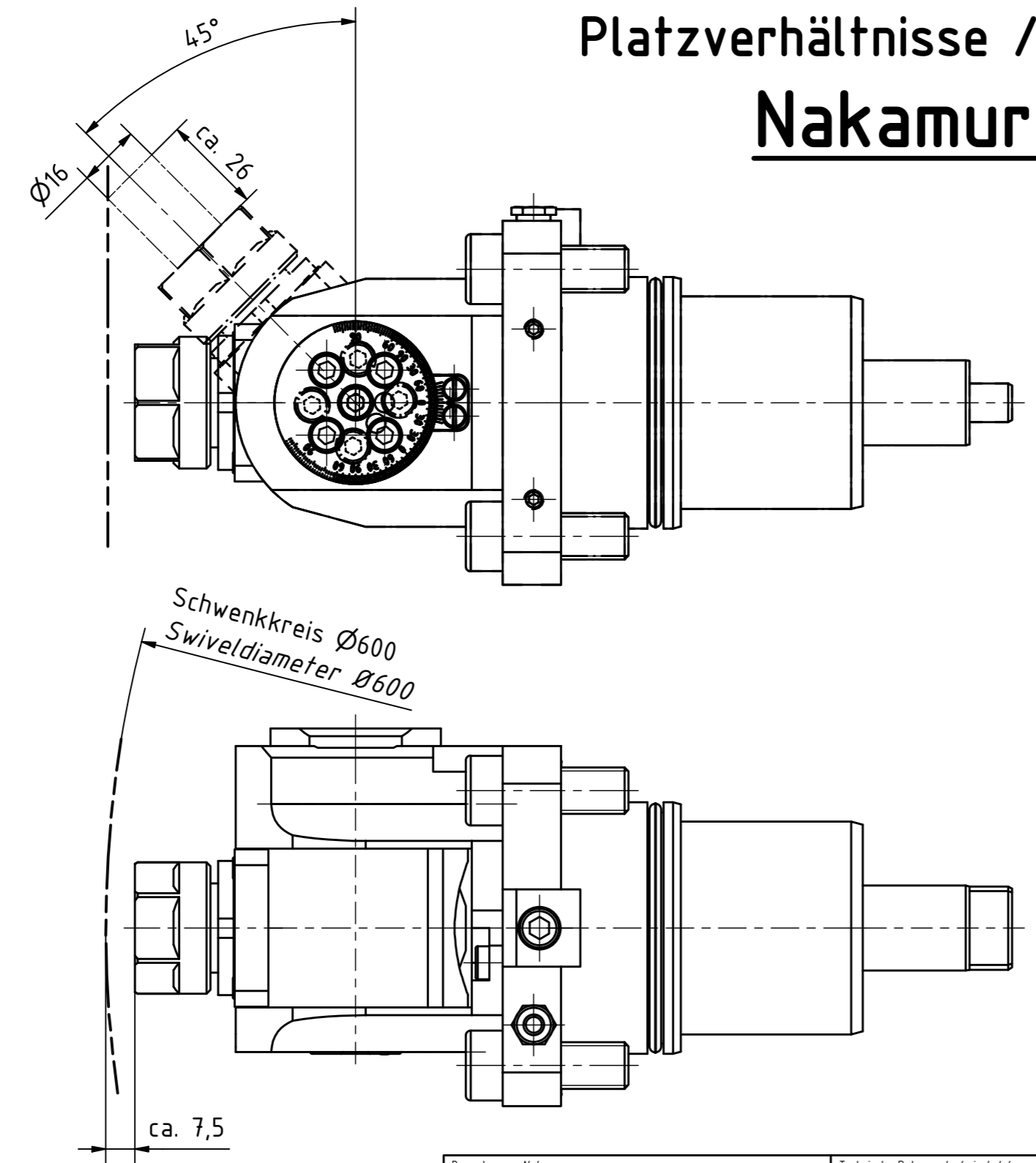

Hakenschlüssel  
 mit Nase  
 Hook wrench with  
 nose end  
 DIN1810 A 34x36

Copyright **EWS Tool Technologies**  
 Weitergabe und Vervielfältigung dieser Unterlage,  
 Verwertung und Mitteilung ihres Inhalts nicht  
 gestattet, soweit nicht ausdrücklich zugestanden.  
 Zuwiderhandlungen verpflichten zu Schadenersatz.

Bemerkung - Note  	Technische Daten - technical data Weight = 4,394 [kg] Torque max. (M1/M2) = 16 / 16 [Nm] Speed max. (n1/n2) = 6000 / 6000 [1/min] Gear ratio (i)=n1:n2 = 1:1	Benennung - Title <b>Schwenkkopf</b> <b>Swivel head</b>	 EWS Weigle GmbH & Co. KG Maybachstr. 1 D-73066 Uhingen www.ews-tools.de Nr. - No. <b>63.6520TW20</b>	Technische Änderungen vorbehalten! Subject to technical modifications! IDENT: DEWS060679 MNR. REV: -/A <b>114943</b>	
--------------------------	--	---	---	---	---