

Schwenkbereich $\pm 105^\circ$
Swivel area $\pm 105^\circ$

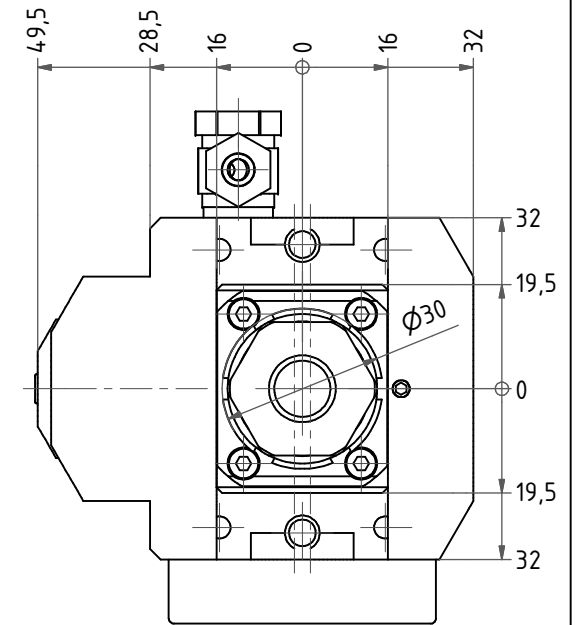

Spannzange / Collet ER16 DIN6499
Spannbereich / Clamping range: 1,0 - 10,0

Gewindebohrzange / Tapping Collet
ET-1-16 M1-M6

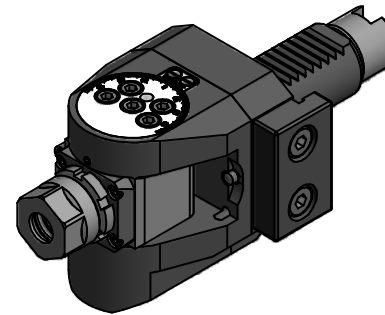

Hakenschlüssel
mit Nase
Hook wrench with
nose end
DIN1810 A 30x32

Copyright **EWS Tool Technologies**
Weitergabe und Vervielfältigung dieser Unterlage,
Verwertung und Mitteilung ihres Inhalts nicht
gestattet, soweit nicht ausdrücklich zugestanden.
Zuwerhandlungen verpflichten zu Schadenersatz.

Bemerkung - Note	Technische Daten - technical data Weight = 2.490 [kg] Torque max. (M1/M2) = 16 / 8 [Nm] Speed max. (n1/n2) = 6000 / 12000 [1/min] Gear ratio (i)=n1:n2 = 1:2	Benennung - Title Schwenkopf Swivel head	 <small>EWS Weigelt GmbH & Co. KG Maybachstr. 1 D-73066 Uhingen www.ews-tools.de</small> Nr. - No. 63.3016G3001	Technische Änderungen vorbehalten! Subject to technical modifications! IDENT: DEWS022689	 REV: -/A MNR. 100833	
------------------	--	--	--	--	--	---