

Spannzangenschlüssel für innenliegende Mutter  
Clamping wrench for internal collet  
220AX

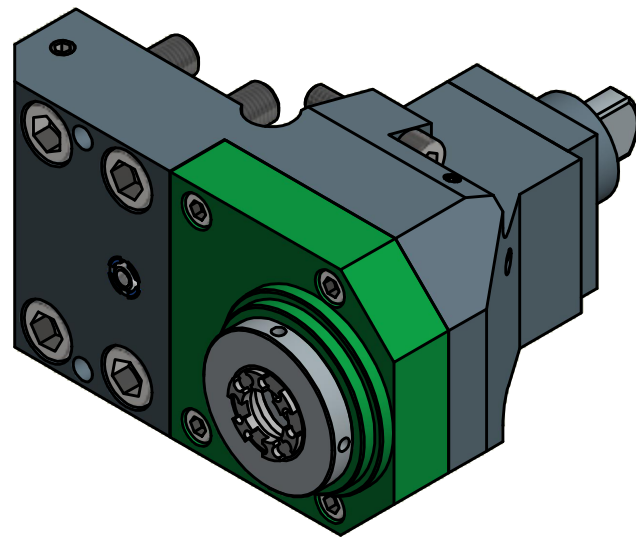

Hakenschlüssel mit Zapfen  
Hook wrench with fixed pin  
DIN1810 B 45x50

Spannzange / collet ER20 DIN6499  
Spannbereich / clamping range: 1,0 - 13,0

Gewindebohrzange / tapping collet  
ET-1-20 M2-M6

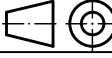

Copyright **EWS Tool Technologies**  
Weitergabe und Vervielfaeltigung dieser Unterlage,  
Verwertung und Mitteilung ihres Inhalts nicht  
gestattet, soweit nicht ausdrecklich zugestanden.  
Zuwiderhandlungen verpflichten zu Schadenersatz.

Bemerkung - Note	Technische Daten - technical data Weight = 5.559 [kg] Torque max. (M1/M2) = 24 / 12 [Nm] Speed max. (n1/n2) = 6000 / 12000 [1/min] Gear ratio (i)=n1:n2 = 1:2	Benennung - Title <b>Axial Bohr u. Fräskopf achsversetzt</b> <b>Ax. drill. and mill. head offset</b>	 <b>EWS</b> Weigele GmbH & Co. KG Maybachstr. 1 D-73066 UHINGEN www.ews-tools.de	Technische Aenderungen vorbehalten! Subject to technical modifications! IDENT: D-EWS-116270	 REV: -/- MNR. <b>121540</b>	
			Nr. - No. <b>50.3220SL150BMT11M</b>			