

Spannzange / collet ER20 DIN6499
 Spannbereich / clamping range: 1,0 - 13,0

Gewindebohrzange / tapping collet
 ET-1-20 M2-M6

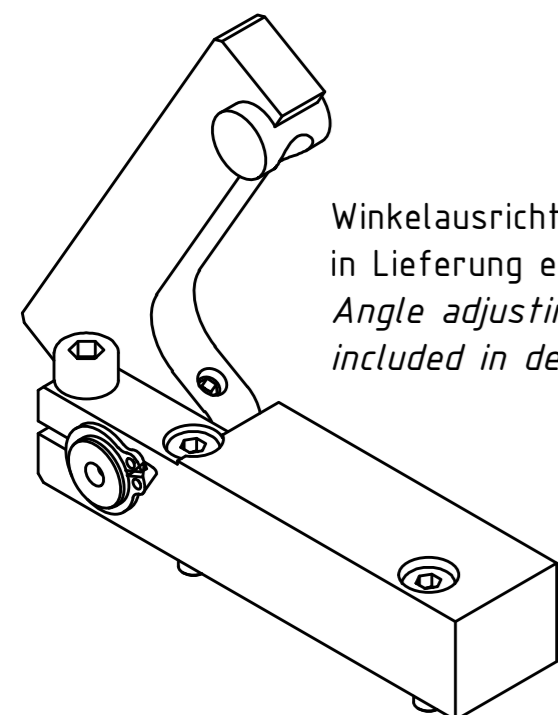

Winkelausrichtung & CD-ROM
 in Lieferung enthalten!
 Angle adjusting & CD-ROM
 included in delivery!

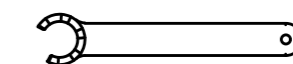
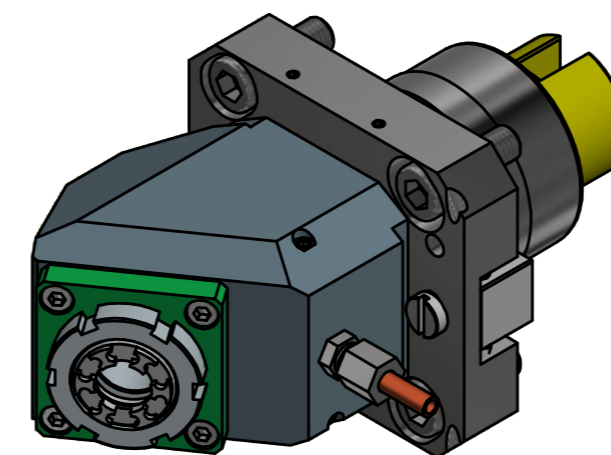

Spannzangenschlüssel für
 innenliegende Mutter
 Clamping wrench for
 internal collet
 220AX

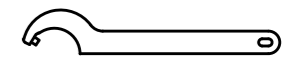

Hakenschlüssel
 mit Zapfen
 Hook wrench
 with fixed pin
 DIN1810 B 40x42

Copyright **EWS Tool Technologies**
 Weitergabe und Vervielfältigung dieser Unterlage,
 Verwertung und Mitteilung ihres Inhalts nicht
 gestattet, soweit nicht ausdrücklich zugestanden.
 Zuwiderhandlungen verpflichten zu Schadenersatz.

Bemerkung - Note mit Kegelrollenlager with taper roller bearing(s)	Technische Daten - technical data Weight = 4,832 [kg] Torque max. (M1/M2) = 25 / 25 [Nm] Speed max. (n1/n2) = 6000 / 6000 [1/min] Gear ratio (i)=n1:n2 = 1:1	Benennung - Title Radial Bohr und Fräskopf Radial drilling and milling head	<table border="1"> <tr> <td data-bbox="2226 1915 2463 1974"> EWS <small>EWS Weigle GmbH & Co. KG Maybachstr. 1 D-73066 Uhlingen www.ews-tools.de</small> </td> <td data-bbox="2463 1915 2671 1974"> Technische Änderungen vorbehalten! Subject to technical modifications! IDENT: DEWS037494 </td> <td data-bbox="2671 1915 2929 1974"> REV: -/A MNR. </td> </tr> <tr> <td data-bbox="2226 1974 2463 2043"> Nr. - No. 60.6020KREX508BMTTKW35IMY0.7 </td> <td data-bbox="2463 1974 2671 2043"> 142104 </td> <td data-bbox="2671 1974 2929 2043"> QR </td> </tr> </table>	EWS <small>EWS Weigle GmbH & Co. KG Maybachstr. 1 D-73066 Uhlingen www.ews-tools.de</small>	Technische Änderungen vorbehalten! Subject to technical modifications! IDENT: DEWS037494	 REV: -/A MNR.	Nr. - No. 60.6020KREX508BMTTKW35IMY0.7	142104	QR
EWS <small>EWS Weigle GmbH & Co. KG Maybachstr. 1 D-73066 Uhlingen www.ews-tools.de</small>	Technische Änderungen vorbehalten! Subject to technical modifications! IDENT: DEWS037494	 REV: -/A MNR.							
Nr. - No. 60.6020KREX508BMTTKW35IMY0.7	142104	QR							