

6 | 5 | 4 | 3 | 2 | 1

D

C

B

A

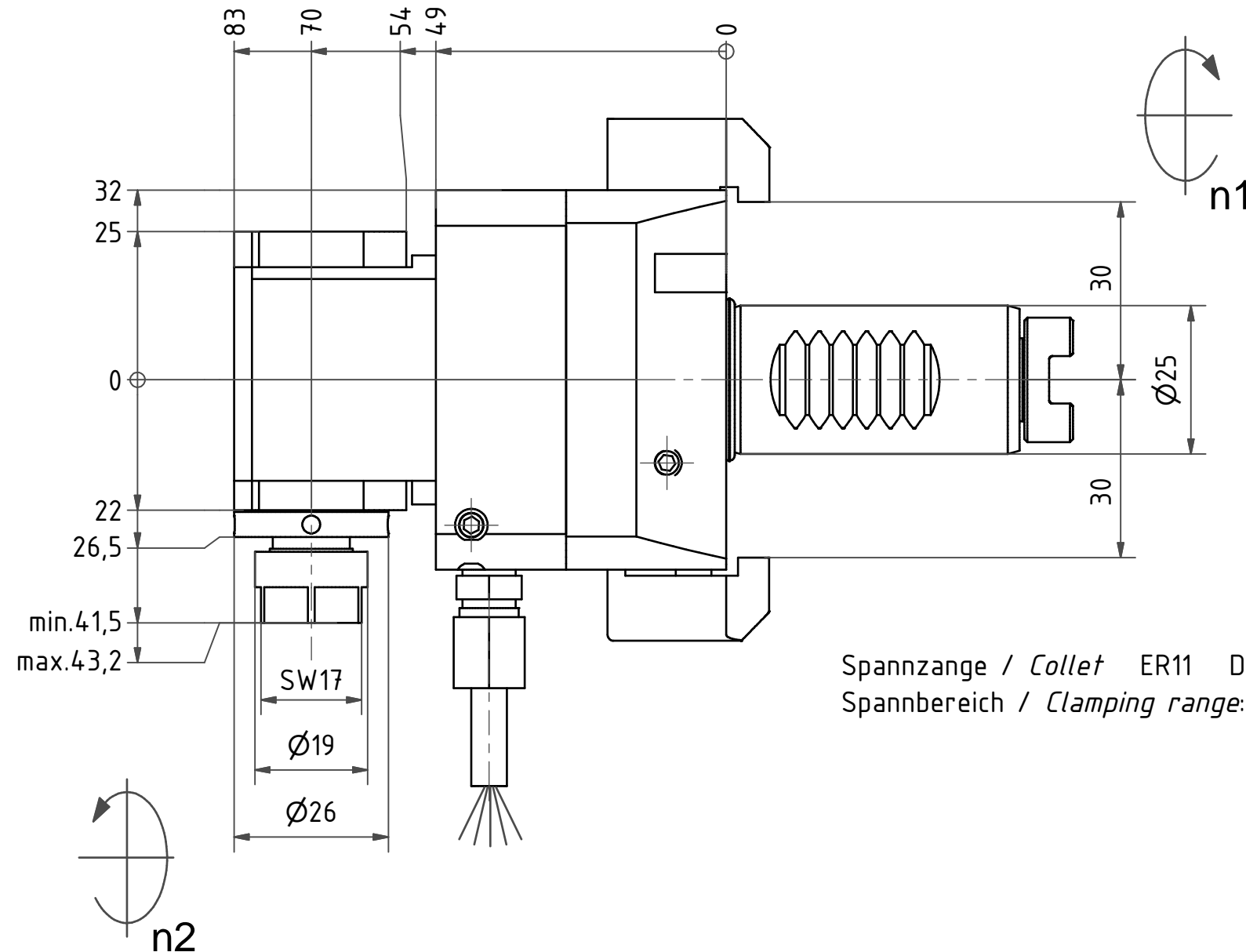

Spannzange / Collet ER11 DIN6499
Spannbereich / Clamping range: 0,5 - 7,0

Doppelverzahnung Lizenz Traub
double tooth system licence Traub

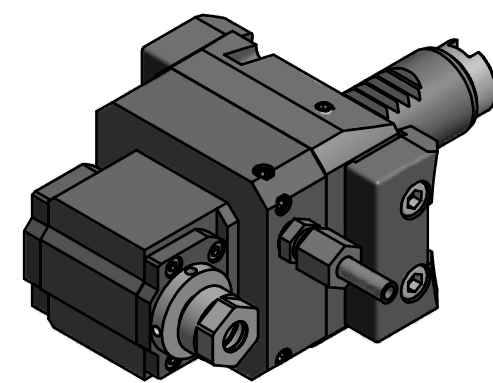
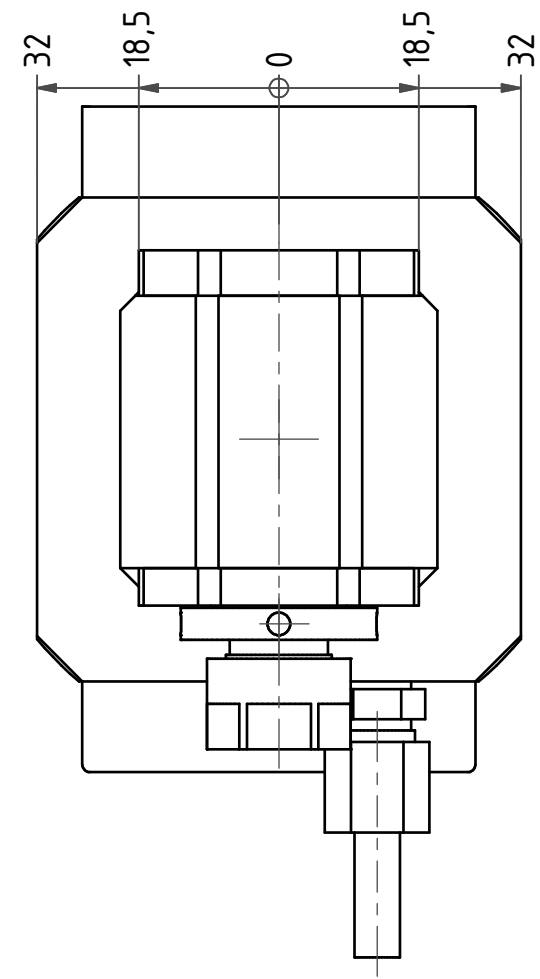
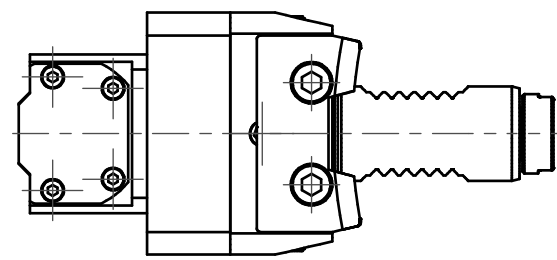

Hakenschlüssel
mit Zapfen
Hook wrench
with fixed pin
DIN1810 B 25x28

Copyright **EWS Tool Technologies**
Weitergabe und Vervielfaeltigung dieser Unterlage,
Verwertung und Mitteilung ihres Inhalts nicht
gestattet, soweit nicht ausdrecklich zugestanden.
Zuwiderhandlungen verpflichten zu Schadenersatz.

Bemerkung - Note	Technische Daten - technical data M1 / M2 = 6,3 / 6,3 Nm n1 / n2 = 8000 / 8000 1/min i (N1:N2) = 1:1	Benennung - Title Radial Bohr und Fräskopf <i>Radial drilling and milling head</i>	name	date	Technische Aenderungen vorbehalten! Subject to technical modifications!	
			drawing	M. Simoniello		
			EWS Weigete GmbH & Co. KG Maybachstr. 1 D-73066 Uhingen Tel. +49(0)7161/93040-100		Nr. 60.2512G200RL	DIN A3
			MNR: 133137		IDENT: D-EWS-186491 -	Blatt - page 1 (1)

6 | 5 | 4 | 3 | 2 | 1