

Spannzange / collet ER40 DIN64.99  
 Spannbereich / clamping range: 3,0 - 26,0

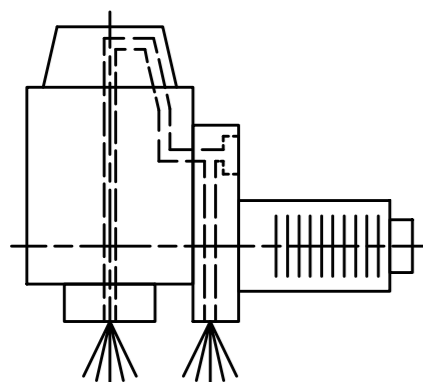

Innen- und Aussenkuehlung / Inside and outside coolant supply  
 Kuehlmittelfiltrierung<math>50\mu</math> / coolant filtration<math>50\mu</math>

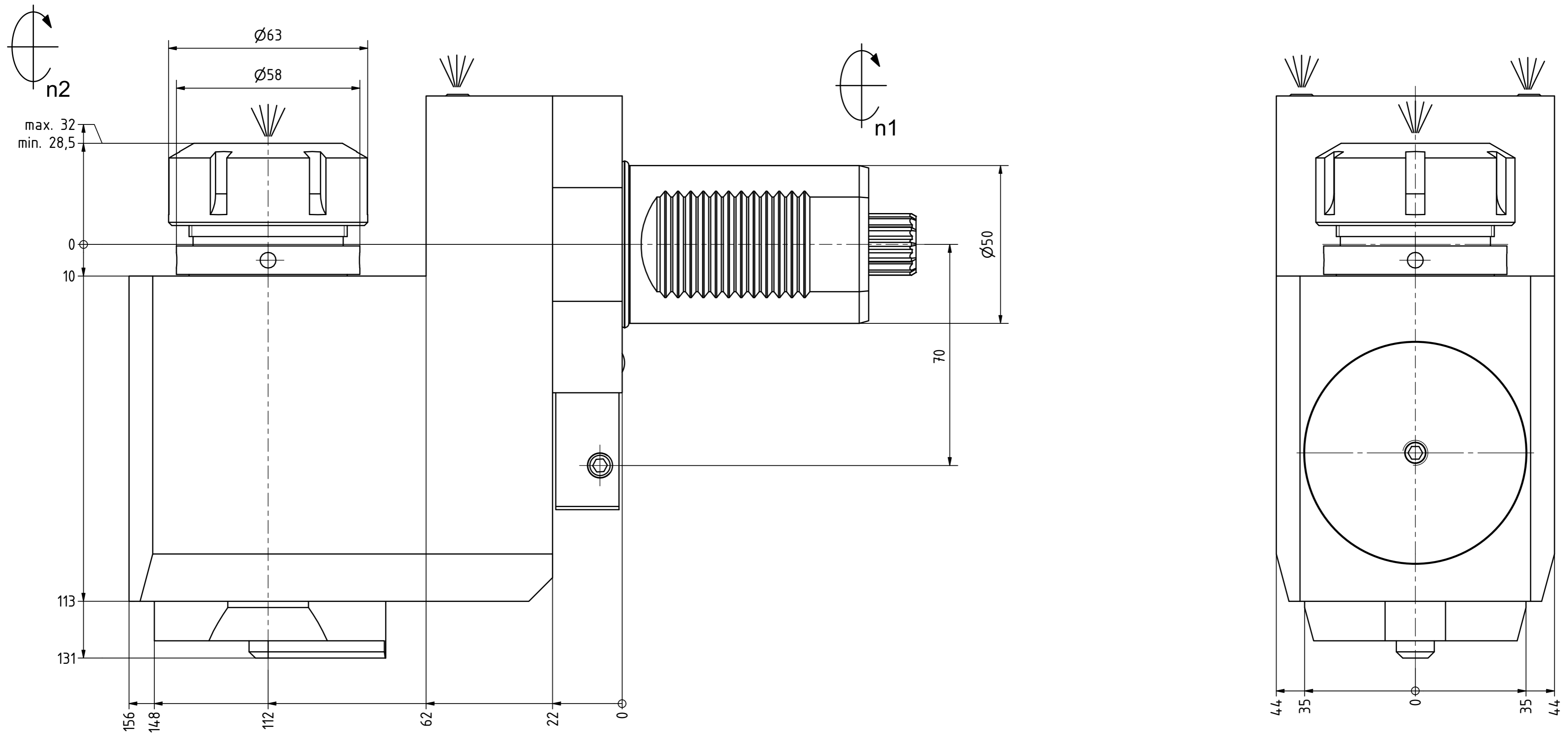
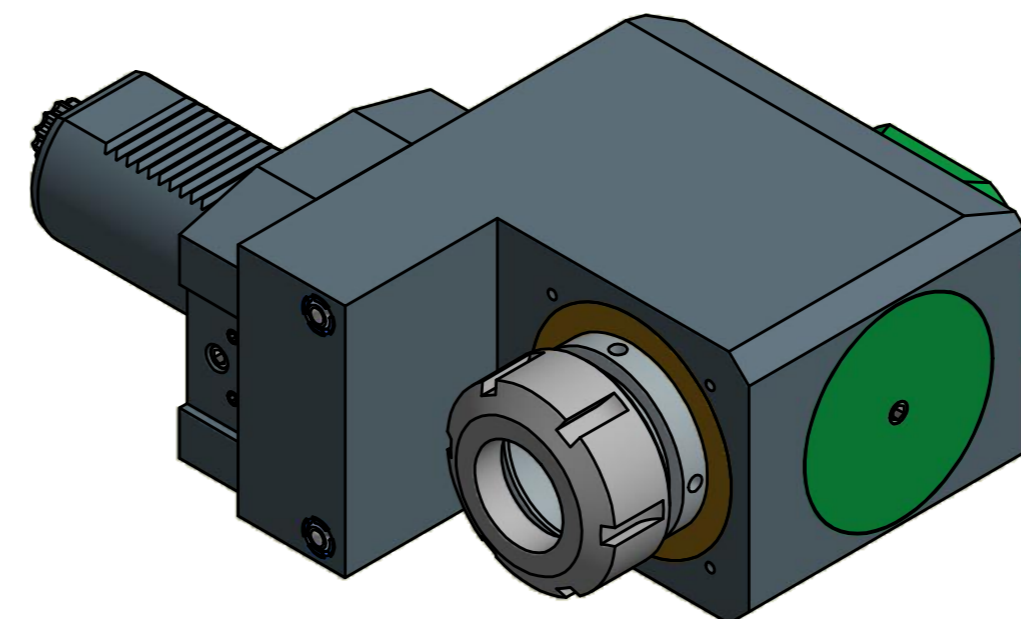

Hakenschlüssel  
 mit Zapfen  
 Hook wrench  
 with fixed pin  
 DIN1810 B 58x62

Spannzangenschlüssel  
 Clamping wrench  
 240

Copyright **EWS Tool Technologies**  
 Weitergabe und Vervielfaeltigung dieser Unterlage,  
 Verwertung und Mitteilung ihres Inhalts nicht  
 gestattet, soweit nicht ausdrecklich zugestanden.  
 Zuwiderhandlungen verpflichten zu Schadenersatz.

<p>Bemerkung - Note                  Für Trockenlauf geeignet!                  Use without coolant fluid allowed!</p>	<p>Technische Daten - technical data                  Weight = 12.084 [kg]                  Torque max. (M1/M2) = 100 / 100 [Nm]                  Speed max. (n1/n2) = 4.000 / 4.000 [1/min]                  Gear ratio (i)=n1:n2 = 1:1                  Pressure (pmax) = 70 [bar]</p>	<p>Benennung - Title                  Radial Bohr und Fräskopf, zurückges                  Radial drill. and mill. head offset</p>	<p><b>EWS</b> Tool Technologies                  EWS Weigle GmbH &amp; Co. KG                  Maybachstr. 1                  D-73066 Uhlingen                  www.ews-tool.de</p>	<p>Technische Aenderungen vorbehalten!                  Subject to technical modifications!                  IDENT: D-EWS-189982</p>	<p>REV: -/-                  MNR.                  133097</p>	<p>QR</p>
--	--	--	---	--	---	-----------

Nr. - No.  
 80.504.054.82.LIKD