

Spannzange / collet ER32 DIN6499
 Spannbereich / clamping range: 2,0 - 20,0

Gewindebohrzange / tapping collet
 ET-1-32 M5-M12

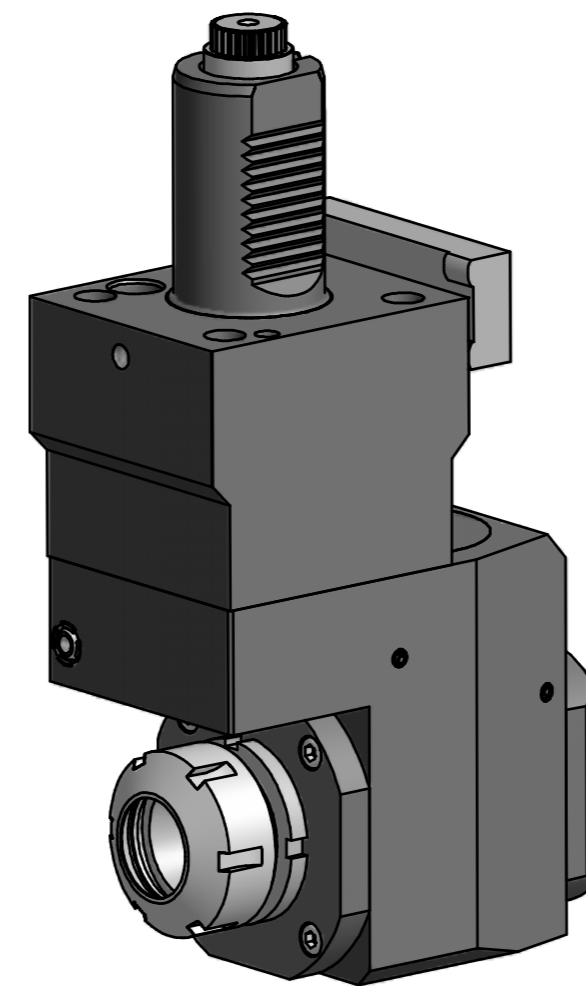
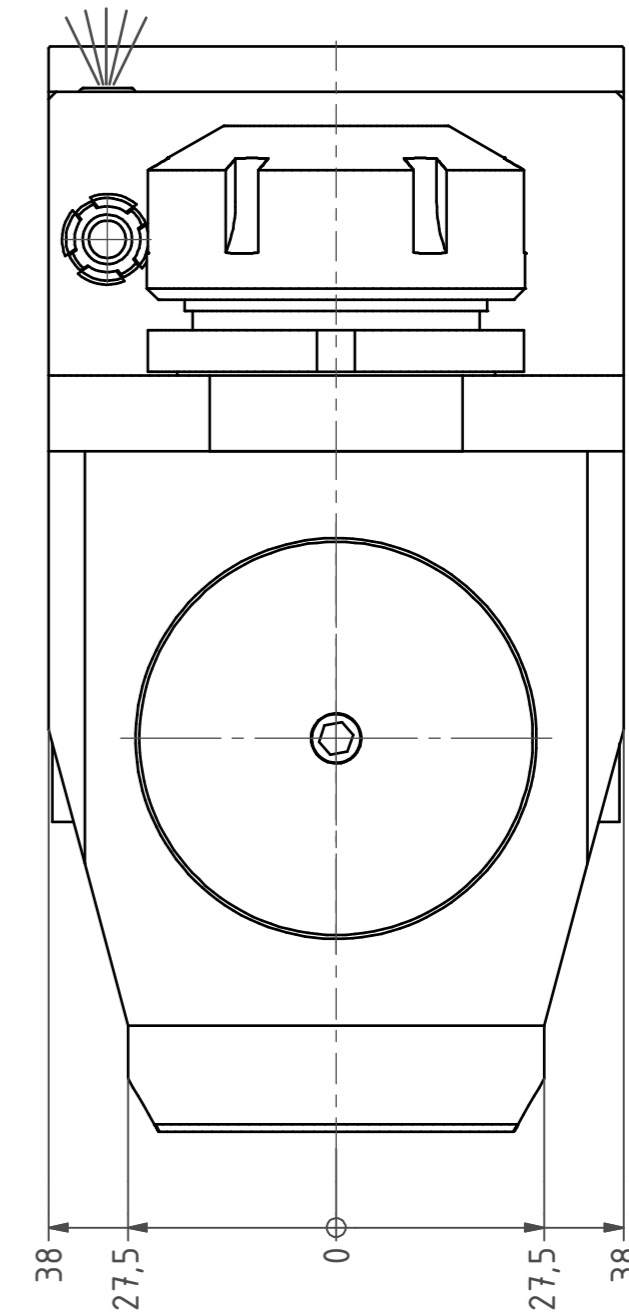
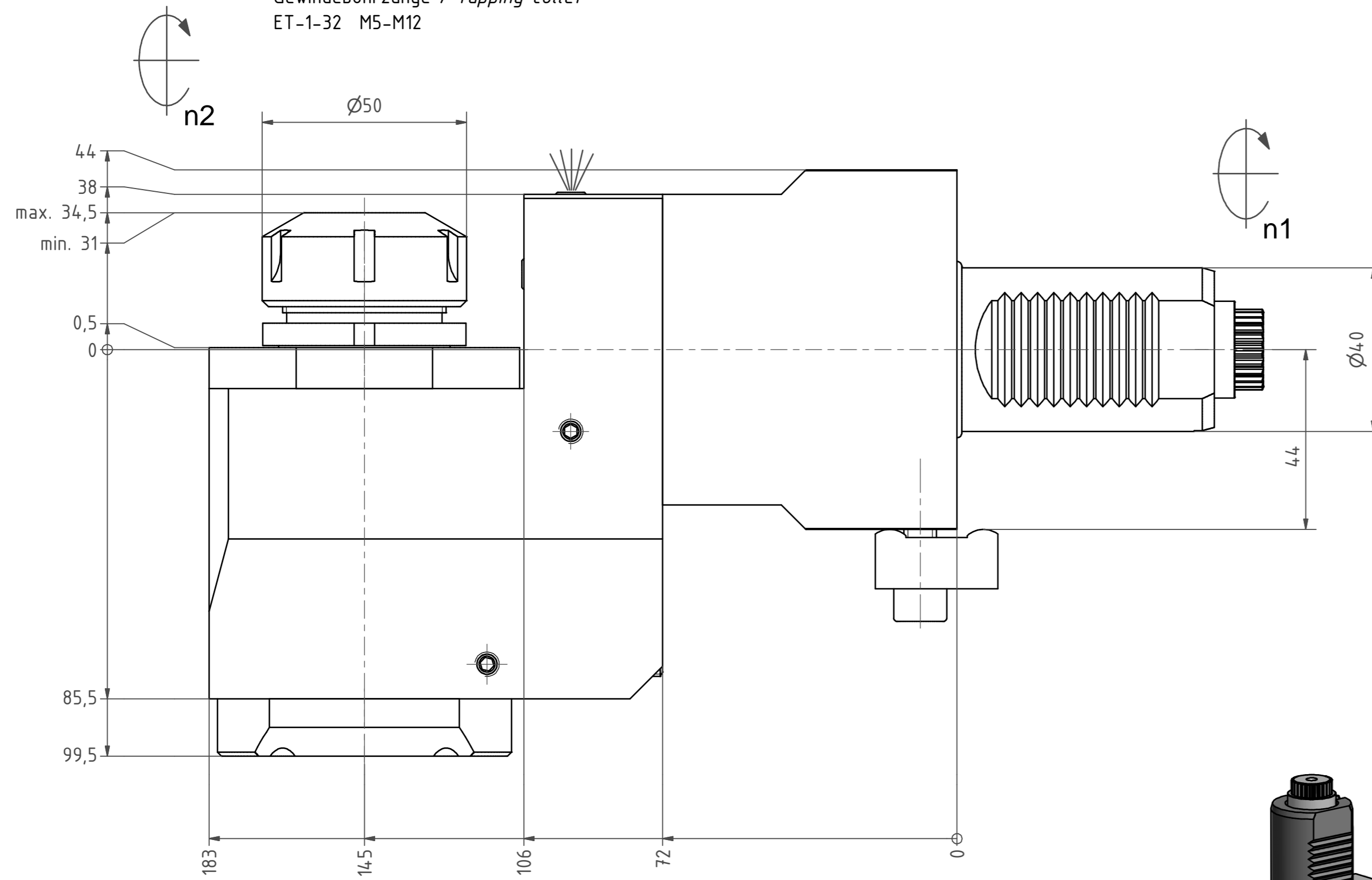

Copyright **EWS Tool Technologies**
 Weitergabe und Vervielfältigung dieser Unterlage,
 Verwertung und Mitteilung ihres Inhalts nicht
 gestattet, soweit nicht ausdrücklich zugestanden.
 Zuwiderhandlungen verpflichten zu Schadenersatz.

Bemerkung - Note	Technische Daten - technical data		Benennung - Title	name	date	Technische Änderungen vorbehalten! Subject to technical modifications!	DIN A2	
	M ₁ / M ₂ = 50 / 50 Nm	M ₁ / n ₂ = 6000 / 6000 1/min						Radial Bohr und Fräskopf. zurückges Radial drill. and mill. head offset
	i (N ₁ :N ₂) = 1:1					MNR: 120848	IDENT: D-EWS-071613	

