

Spannzange / collet ER25 DIN6499
 Spannereich / clamping range: 1,0 - 16,0

max. 67
 min. 63,5

n2

Ø40

54

≥1

Ø30

Ø42

42

35

0

32

51

59,5

126

100

57

0

32

23

0

23

32

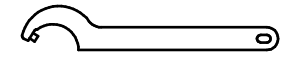

Hakenschlüssel
 mit Zapfen
 Hook wrench
 with fixed pin
 DIN1810 B 40x42



Spannzangenschlüssel
 Clamping wrench
 DIN1810 B 40x42 225

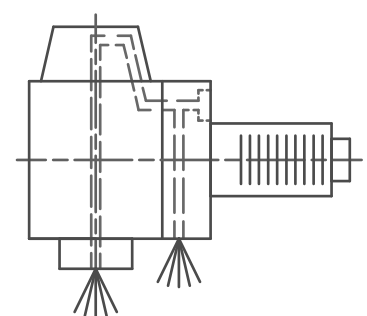
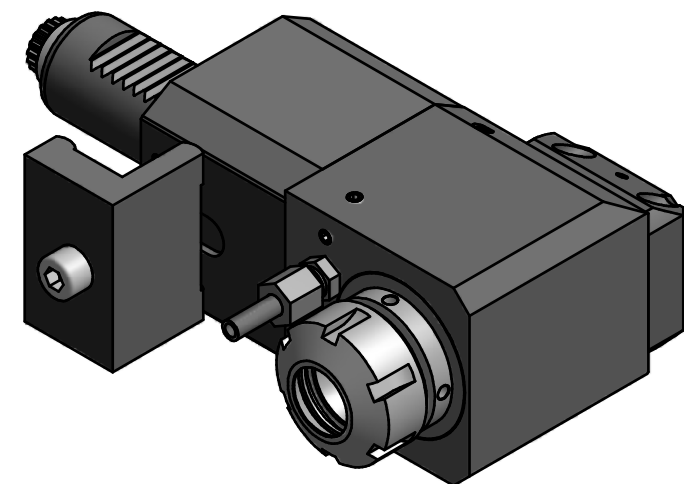

Innen- und Aussenkuehlung / Inside and outside coolant supply
 Kein Trockenlauf / No dry run
 Kuehlmittelfiltrierung < 50µ / coolant filtration < 50µ

Copyright **EWS Tool Technologies**
 Weitergabe und Vervielfaeltigung dieser Unterlage,
 Verwertung und Mitteilung ihres Inhalts nicht
 gestattet, soweit nicht ausdruuecklich zugestanden.
 Zuwiderhandlungen verpflichten zu Schadenersatz.

Bemerkung - Note Nicht ohne Kuehlmittel betreiben! Not for use without coolant-fluid!	Technische Daten - technical data M1 / M2 = 25 / 25 Nm n1 / n2 = 8000 / 8000 1/min i (N1:N2) = 1:1 pmax = 70 bar	Benennung - Title Radial Bohr und Fräskopf <i>Radial drilling and milling head</i>	name Theiss	date 05.11.2013	Technische Aenderungen vorbehalten! Subject to technical modifications! Nr. 60.3025LCTXLIKOT08 MNR: 114361 IDENT: D-EWS-146291 A Blatt - page 1 (1)
			EWS Weigele GmbH & Co. KG Maybachstr. 1 D-73066 Uhingen Tel. +49(0)7161/93040-100		