

Innen- und Aussenkuehlung / Inside and outside coolant supply
Kuehlmittelfiltrierung <math>< 50\mu</math> / coolant filtration <math>< 50\mu</math>

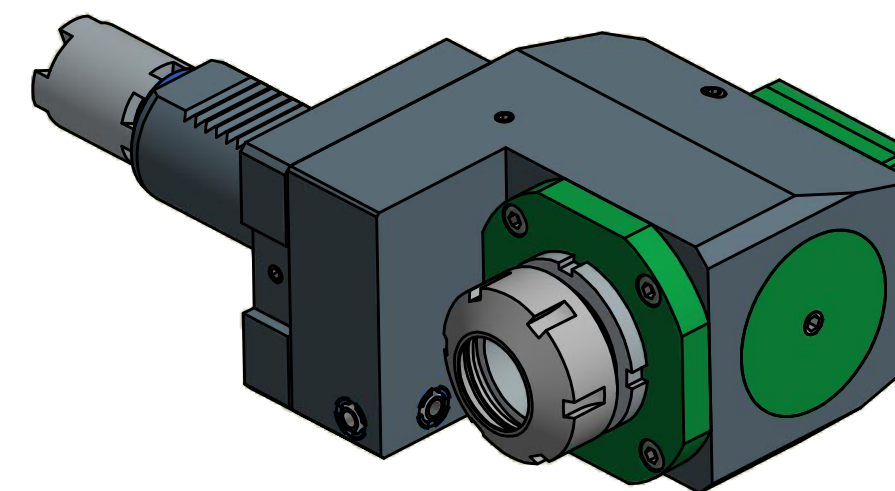

Hakenschlüssel
mit Nase
Hook wrench with
nose end
DIN1810 A 45x50

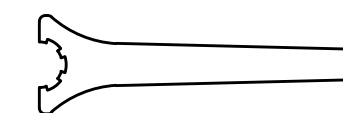

Spannzangenschlüssel
Clamping wrench
232

Copyright **EWS Tool Technologies**
Weitergabe und Vervielfaeltigung dieser Unterlage,
Verwertung und Mitteilung ihres Inhalts nicht
gestattet, soweit nicht ausdrecklich zugestanden.
Zuwaerhandlungen verpflichten zu Schadenersatz.

Bemerkung - Note
Für Trockenlauf geeignet!
Use without coolant fluid allowed!

Technische Daten - technical data
Weight = 6.825 [kg]
Torque max. (M1/M2) = 50 / 50 [Nm]
Speed max. (n1/n2) = 6000 / 6000 [1/min]
Gear ratio (i)=n1:n2 = 1:1
Pressure (pmax) = 70 [bar]

Benennung - Title
Radial Bohr und Fräskopf, zurückges
Radial drill. and mill. head offset



Nr. - No.
80.4032HAASSL20LIKD

Technische Aenderungen vorbehalten!
Subject to technical modifications!
IDENT: D-EWS-163997

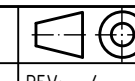

REV: -/-
MNR.
132879

