

Spannzange / collet ER25 DIN6499
 Spannereich / clamping range: 1,0 - 16,0

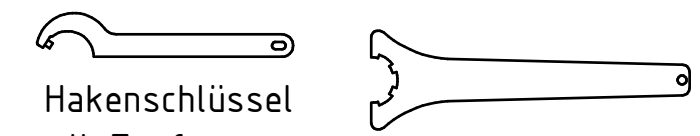

Hakenschlüssel mit Zapfen
 Hook wrench with fixed pin
 DIN1810 B 40x42

Spannzangenschlüssel
 Clamping wrench
 225

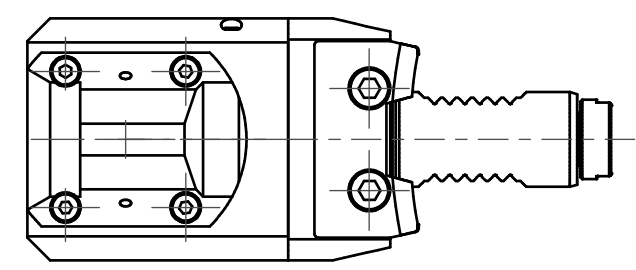
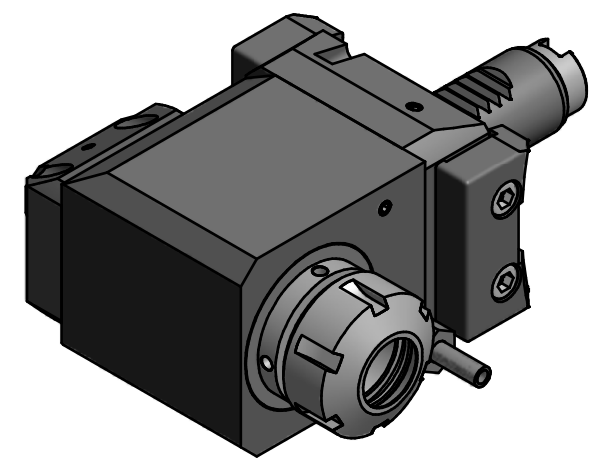

Doppelverzahnung Lizenz Traub
 double tooth system licence Traub

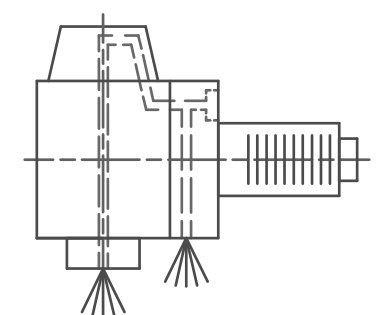

Innen- und Aussenkuehlung / Inside and outside coolant supply
 Kein Trockenlauf / No dry run
 Kuehlmittelfiltrierung $= 50\mu$ / coolant filtration $= 50\mu$

Copyright **EWS Tool Technologies**
 Weitergabe und Vervielfaeltigung dieser Unterlage, Verwertung und Mitteilung ihres Inhalts nicht gestattet, soweit nicht ausdruuecklich zugestanden. Zuwiderhandlungen verpflichten zu Schadenersatz.

| | | | | | | |
|---|--|---|--|--------------------|--|--|
| Bemerkung - Note Nicht ohne Kuehlmittel betreiben! Not for use without coolant-fluid! | Technische Daten - technical data M1 / M2 = 20 / 40 Nm n1 / n2 = 6000 / 3000 1/min i (N1:N2) = 2:1 pmax = 70 bar | Benennung - Title Radial Bohr und Fräskopf <i>Radial drilling and milling head</i> | name M. Simoniello | date 17.09.2015 | Technische Aenderungen vorbehalten! Subject to technical modifications! | |
| | | | EWS Weigete GmbH & Co. KG Maybachstr. 1 D-73066 Uhingen Tel. +49(0)7161/93040-100 | | | |