

Spannzange / collet ER20 DIN6499  
 Spannbereich / clamping range: 1,0 - 13,0

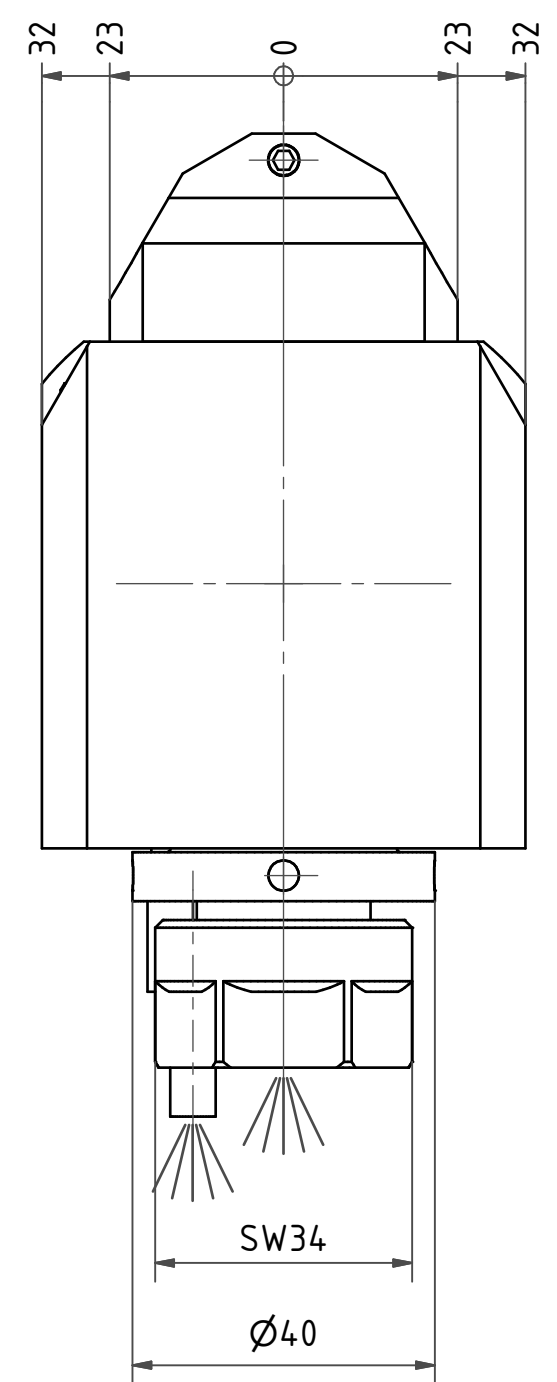

Hakenschlüssel  
 mit Zapfen  
 Hook wrench  
 with fixed pin  
 DIN1810 B 40x42

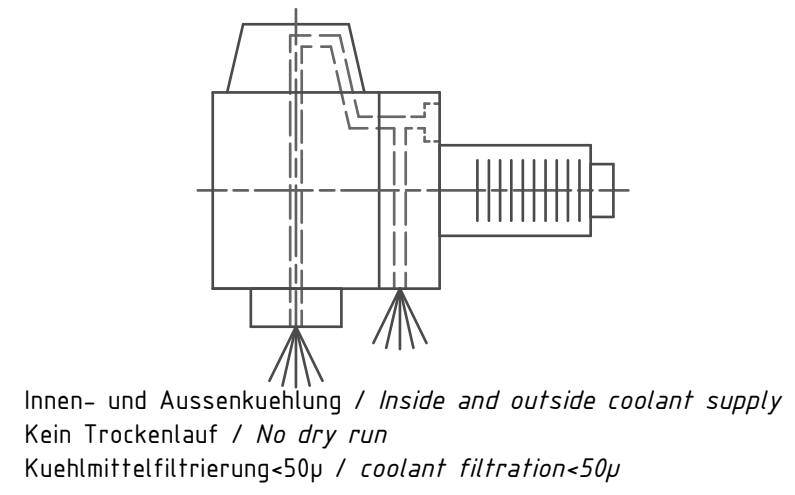
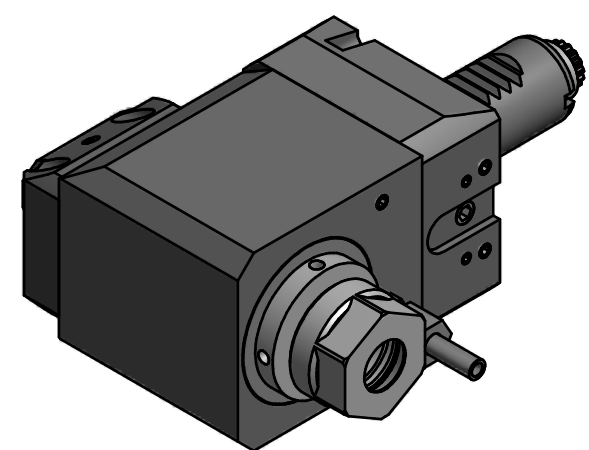

Innen- und Aussenkuehlung / Inside and outside coolant supply  
 Kein Trockenlauf / No dry run  
 Kuehlmittelfiltrierung < 50µ / coolant filtration < 50µ

Copyright **EWS Tool Technologies**  
 Weitergabe und Vervielfaeltigung dieser Unterlage,  
 Verwertung und Mitteilung ihres Inhalts nicht  
 gestattet, soweit nicht ausdruuecklich zugestanden.  
 Zuwiderhandlungen verpflichten zu Schadenersatz.

<p>Bemerkung - Note          Nicht ohne Kuehlmittel betreiben!          Not for use without coolant-fluid!</p>	<p>Technische Daten - technical data          M1 / M2 = 24 / 12 Nm          n1 / n2 = 6000 / 12000 1/min          i (N1:N2) = 1:2          pmax = 70 bar</p>	<p>Benennung - Title  <b>Radial Bohr und Fräskopf</b>  <b>Radial drilling and milling head</b></p>	<table border="1"> <tr> <th>name</th> <th>date</th> </tr> <tr> <td>M. Simoniello</td> <td>06.02.2013</td> </tr> </table>	name	date	M. Simoniello	06.02.2013	<p>Technische Aenderungen vorbehalten!          Subject to technical modifications!</p> <p>Nr.  <b>60.2520L5480RIK1</b></p> <p>DIN A3</p> <p>MNR: 113525 IDENT: D-EWS-131756 - Blatt - page 1 (1)</p>
name	date							
M. Simoniello	06.02.2013							